

TM-733A/E

SERVICE MANUAL

KENWOOD

© 1994-3 PRINTED IN JAPAN
B51-8264-00(N)1501

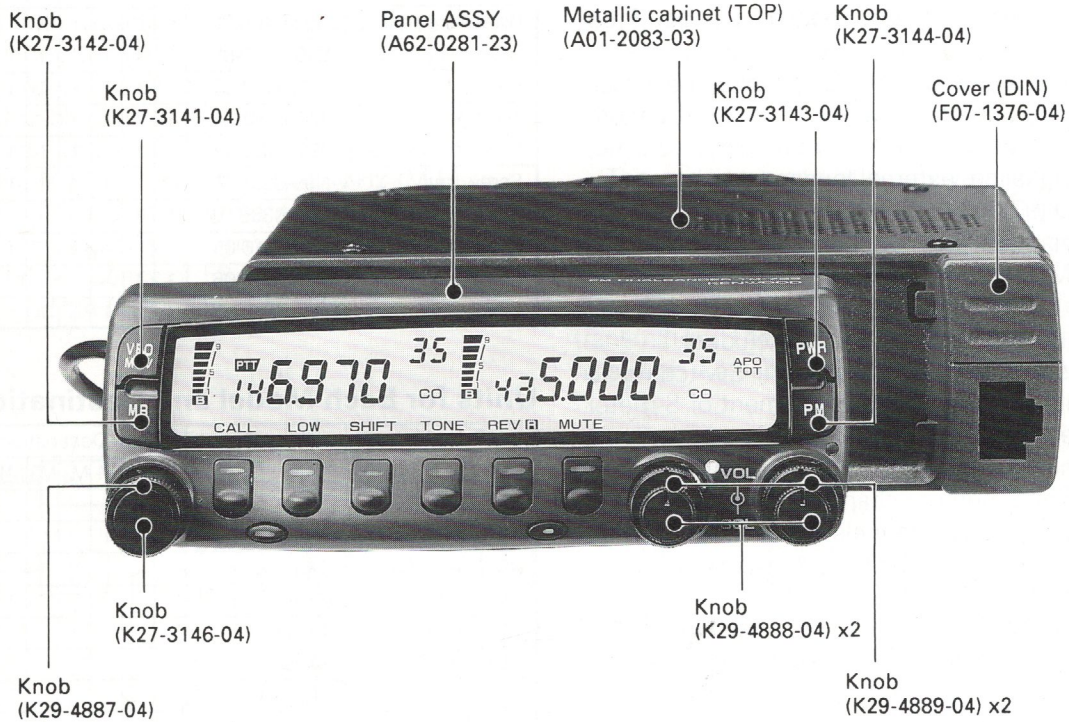

CONTENTS

CIRCUIT DESCRIPTION	2	TX-RX UNIT (X57-436X-XX) (B/4, D/4)	69
SEMICONDUCTOR DATA	23	TX-RX UNIT (X57-436X-XX) (C/4)	73
DESCRIPTION OF COMPONENTS	26	LCD ASSY (B38-070X-25)	74
PARTS LIST	30	SCHEMATIC DIAGRAM	75
EXPLODED VIEW	49	BLOCK DIAGRAM	77
PACKING	51	LEVEL DIAGRAM	79
ADJUSTMENT	52	TERMINAL FUNCTION	80
PC BOARD VIEWS/CIRCUIT DIAGRAMS		OPTION (DFK-3B/4B/7B)	81
TX-RX UNIT (X57-436X-XX) (A/4)	61	SPECIFICATIONS	BACK COVER

CIRCUIT DESCRIPTION

Outline

The TM-733A/E are 144/430MHz FM dual band car transceivers designed for armature radio communications.

• Features

1. The current operating state can be stored in six programmable memory channels.
2. Complete compact dual band function.
3. The extended cable kit (option) can be used to disconnect the panel with one touch of a finger. Free setting is made possible.
4. Independent receiving function enables the simultaneous receiving of 144MHz and 430MHz bands. (Both bands independent, full display, volume, squelch, signaling, external loudspeaker.)
5. Large LCD (97.0 x 19.0 mm).
6. Simple operation like monoband type.
7. Both 144MHz and 430MHz bands can be received at a time.
8. Duplexer built in (Types K and P excluded).
9. S-meter squelch function built in. Switching to noise squelch provides the adjustment of S-meter squelch level with a squelch volume.
10. With a maximum of 70 memory channels, the switching of a memory channel mode permits the number of memory channels for each band to be changed. (All channels in full split memory)
11. DTSS and paging functions built in.
12. Wireless (DTMF) coulomb function built in.
13. Equipped with packet communication connector.

Accessories

Parts name	Parts No.	Destination code									
		K	P	M	M2	M3	M4	E	E2	E3	E9
Warranty card	B46-0310-03							1		1	1
Warranty card	B46-0410-30	1									
Warranty card	B46-0422-00		1								
Instruction manual	B62-0391-00	1	1	1	1	1	1	1	1	1	1
Instruction manual	B62-0392-00							1	1		
Instruction manual	B62-0393-00		1	1	1	1				1	
Instruction manual	B62-0394-00		1	1	1	1				1	1
Instruction manual	B62-0466-00						1				
DC power cord	E30-2111-05	1	1	1	1	1	1	1	1	1	1
Fuse (15A)	F51-0017-05	1	1	1	1	1	1	1	1	1	1
Mic hook	J20-0319-24	1	1								
Mobile mount bracket	J29-0436-03	1	1	1	1	1	1	1	1	1	1
Screw set	N99-0331-05			1	1	1	1	1	1	1	1
Screw set	N99-0382-05	1	1								
Microphone	T91-0516-05			1	1		1	1	1	1	1
Microphone	T91-0517-05	1	1			1					
Spanner	W01-0414-04	1	1	1	1	1	1	1	1	1	1

Units for Each Model and Destination

Parts No.	Unit name	Destination code									
		K	P	M	M2	M3	M4	E	E2	E3	E9
X57-4360-11	TX-RX unit	1	1								
X57-4360-21	TX-RX unit			1							
X57-4360-22	TX-RX unit				1	1					
X57-4360-23	TX-RX unit						1				
X57-4362-71	TX-RX unit							1		1	1
X57-3462-72	TX-RX unit								1		
B38-0708-25	LCD Ass'y						1				
B38-0709-25	LCD Ass'y	1	1	1	1	1		1	1	1	1

List of Destinations

Model	Destination	Destination code	Frequency range (MHz)				Output power (W)	
			144		430		144	430
TM-733A	North America	K	TX	144.00~147.995	TX	438.00~449.995	50	35
			*1 RX	118.00~173.995	*3 RX	410.00~469.995		
TM-733A	Canada	P	TX	144.00~147.995	TX	438.00~449.995	50	35
			*1 RX	118.00~173.995	*3 RX	410.00~469.995		
TM-733A	Other countries	M		144.00~147.995		430.00~439.995	50	35
TM-733A	Other countries	M2	TX	136.00~173.995	*2	410.00~469.995	50	35
			*1 RX	118.00~173.995				
TM-733A	Other countries	M3	TX	136.00~173.995	*2	410.00~469.995	50	35
			*1 RX	118.00~173.995				
TM-733A	China	M4	TX	136.00~173.995	*2	410.00~469.995	50	35
			*1 RX	118.00~173.995				
TM-733E	European countries	E,E3,E9		144.00~145.995		430.00~439.995	50	35
TM-733E	European countries	E2	TX	136.00~173.995	*2	410.00~469.995	50	35
			*1 RX	118.00~173.995				

*1 : Guarantee frequency range 144.00~147.995

*2 : Guarantee frequency range 430.00~439.995

*3 : Guarantee frequency range 438.00~449.995

CIRCUIT DESCRIPTION

Frequency Configuration

The TM-733A/E has separate PLL and IF units for the VHF and UHF bands, so it can receive signals on both bands at the same time. It has a VHF sub-receiver to receive a UHF signal in the VHF band and a UHF sub-receiver to receive the VHF band signal in the UHF band.

The 144MHz band receiver mixes the received signal with the first local oscillation frequency of 163.05 to 219.045MHz (K,P), 189.05 to 191.045MHz (M,E) to produce the first intermediate frequency of 45.05MHz. The signal is then mixed with the second local oscillation frequency of 45.505MHz to produce the second intermediate frequency of 455kHz.

The 430MHz band receiver mixes the received signal with the first local oscillation frequency of 351.475 to 411.47MHz (K,P), 371.475 to 381.47MHz (M,E) to produce the first intermediate frequency of 58.525MHz. The signal is then mixed with the second local oscillation frequency of 58.0MHz to produce the second intermediate frequency of 455kHz.

The 144MHz band sub-receiver mixes the received signal with the first local oscillation frequency of 118.525 to 232.52MHz (K,P), 202.525 to 206.52MHz (M), 202.525 to 204.52 MHz (E) to produce the first intermediate frequency of 58.525MHz. The signal then goes to the second intermediate frequency section of the UHF receiver to produce the second intermediate frequency of 455kHz.

The 430MHz band sub-receiver mixes the received signal with the first local oscillation frequency of 364.95 to 424.945MHz (K,P), 384.95 to 394.945MHz (M,E) to produce the first intermediate frequency of 45.05MHz. The signal then goes to the second intermediate frequency section of the VHF receiver to produce the second intermediate frequency of 455kHz.

The receivers and sub-receivers for the 144 and, 430MHz bands all use double conversion. The transmitter contains a PLL circuit that directly generates and divides down carriers for both bands. The transmission signals are amplified by a linear amplifier and transmitted. The main circuits are used to transmit signals even if a sub-band is being used.

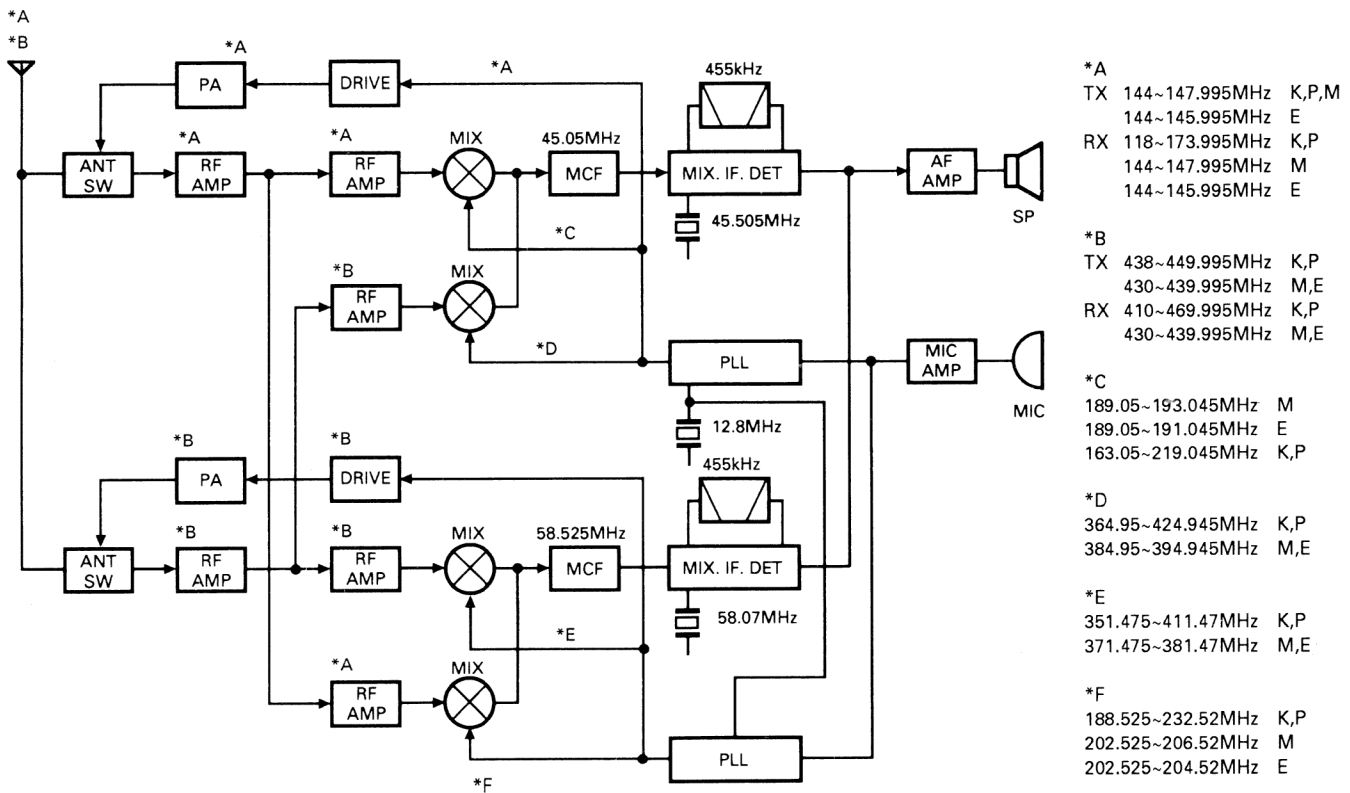

Fig.1 Frequency configuration

CIRCUIT DESCRIPTION

144MHz Band Transmit Circuit

- **Outline**

The transmit circuit produces the desired carrier frequency directly, and directly modulates its frequency by means of a vari-cap diode.

- **Modulator circuit**

The audio signal amplified and limited by the control unit passes through a splatter filter, is mixed with the sub-tone from the microcomputer, and input to PLL unit HIC IC9. The PLL unit directly modulates the carrier frequency with the input audio signal by using a vari-cap diode to control the frequency of the VCO.

- **Younger-stage circuit**

The signal output from the PLL unit goes to drive circuit HIC IC10 (KCB11). The HIC can provide a stable drive output for the final module without adjustment because it has a large bandwidth.

- **Power amplifier circuit**

The drive signal input to the power module according to the output power is amplified to the specified level.

- **APC and power switching circuits**

The automatic transmission output control circuit (APC) detects and partially amplifies the transmission output with a diode, and controls the DB voltage for the drive stage and final module to keep the transmit output constant. The power switching circuit can switch the power by changing the setting resistor for the APC control voltage with a signal from the shift register (IC8).

430MHz Band Transmit Circuit

- **Outline**

The transmit circuit produces the desired carrier frequency directly and directly modulates its frequency by means of a vari-cap diode.

- **Modulator circuit**

The audio signal amplified and limited by the control unit passes through a splatter filter, is mixed with the sub-tone from the microcomputer, and input to PLL unit (KCH20) IC207. The PLL unit directly modulates the carrier frequency with the input audio signal by using a vari-cap diode to control the frequency of the VCO.

- **Younger stage circuit**

The signal output from the PLL unit goes to drive circuit HIC IC209. The HIC can provide stable drive output for the final module without adjustment because it has a large bandwidth.

- **Power amplifier circuit**

The drive signal input to the power module according to the output power is amplified to the specified level.

- **APC and power-switching circuits**

The automatic transmission output control circuit (APC) detects and partially amplifies the transmission output with a diode, and controls the DB voltage for the drive stage and final module to keep the transmit output constant. The power switching circuit can switch the power by changing the setting resistor for the APC control voltage with a signal from the shift register (IC206). To protect the high power model from excessive temperature rise, there is a thermal switch to reduce the power automatically if the temperature reaches a certain level.

CIRCUIT DESCRIPTION

144MHz Band Receive Circuit

The received 144MHz band signal from the antenna passes through a transmission/reception selection diode switch. The signal then passes through an antenna matching coil in the receiver front end and a divider, and is amplified by a joint type field-effect transistor. The unwanted components of the signal are eliminated by a band-pass filter consisting of a three stage variable capacitor. The resulting signal goes to the first mixer, is mixed with the first local oscillator signal from the PLL circuit, and so converted to the first intermediate frequency of 45.05MHz. The unwanted near by signal components are eliminated by a two stage MCF.

The first intermediate frequency signal is amplified and input to FM IF HIC IC1 (KCD04). This signal is then mixed with the second local oscillation frequency of 45.505MHz to produce the second intermediate frequency signal of 455kHz. The unwanted near by signal components are eliminated by an FM ceramic filter. The resulting signal is input to IC1 again, amplified, and detected to produce an audio signal.

- **Signal strength meter**

The signal strength meter output voltage of FM IF HIC IC1 (KCD04) is input to the control unit. It is then digitized to drive the bar meter of the LCD.

Item	Rating
Center frequency	45.050MHz
Pass bandwidth	±7.5kHz or more at 3dB
Attenuation bandwidth	±22kHz or less at 25dB
Guaranteed attenuation	80dB or more within Fo - (890~930kHz) (Spurious : 40dB or more within ±1MHz)
Ripple	1dB or less
Insertion loss	3dB or less
Terminating impedance	800Ω ± 10%, 2pF ± 10%

Table 1 MCF (L71-0443-05) (TX-RX unit XF1)

Item	Rating
Nominal center frequency	455kHz
6dB bandwidth	±6.0kHz or more (from 455kHz)
50dB bandwidth	±12.5kHz or less (from 455kHz)
Ripple	3dB or less (within 455kHz ±5kHz)
Insertion loss	6dB or less (at maximum output point)
Guaranteed attenuation	35dB or more (within 455kHz ±100kHz)
I/O matching terminating impedance	2.0kΩ

**Table 2 Ceramic filter (L72-0400-05)
(TX-RX unit CF1, CF201)**

430MHz Band Receive Circuit

The incoming 430MHz band signal from the antenna passes through a transmission/reception selection diode switch in the final unit and a matching coil in the front end. The signal is amplified by a GaAs field-effect transistor (FET) and passes through a divider and a two-pole dielectric filter to eliminate unwanted signal components. The resulting signal is amplified by a GaAs FET, passes through a two-pole dielectric filter, and goes to the first mixer, is mixed with the first local oscillator signal from the PLL circuit, and so converted to the first intermediate frequency of 58.525MHz. The unwanted near-by signal components are eliminated by a two stage MCF. The first intermediate frequency signal is amplified and input to FM IF HIC IC201 (KCD04). This signal is then mixed with the second local oscillation frequency of 58.07MHz to produce the second intermediate frequency signal of 455kHz. The unwanted near by signal components are eliminated by a ceramic filter. The resulting signal is amplified, and detected to produce an audio signal.

- **Signal-strength meter**

The signal strength meter output voltage of FM IF HIC IC201 (KCD04) is input to the control unit micro-computer to drive the signal strength meter.

Item	Rating
Center frequency	58.525MHz
Pass bandwidth	±8.5kHz or more at 3dB
Attenuation bandwidth	±23kHz or less at 25dB ±60kHz or less at 60dB
Guaranteed attenuation	80dB or more within ±1000kHz (Spurious : 40dB or more within ±1MHz)
Ripple	1dB or less
Insertion loss	4dB or less
Terminating impedance	380Ω ± 10%, 3.5pF ± 10%

Table 3 MCF (L71-0447-05) (TX-RX unit XF201)

CIRCUIT DESCRIPTION

144MHz Band Sub Receive Circuit

The received signal from the antenna goes to the receiver front end for the 144MHz main band. The signal is amplified by a GaAs (gallium arsenide) field-effect transistor (Q1), input to the main 144MHz main circuit and sub circuit by the divider circuit, and input to the 430MHz band sub circuit. The unwanted signal components are eliminated by the filter circuit of the sub-receive circuit, and the resulting signal is amplified by

transistor Q211. The unwanted signal components are further eliminated by another filter circuit. The resulting signal is then mixed with the first local oscillator frequency by the FET (Q212) mixer to produce the first intermediate frequency signal of 58.525MHz. The signal is input to the 430MHz band main circuit, and the 144MHz sub band signal is received by the main circuit.

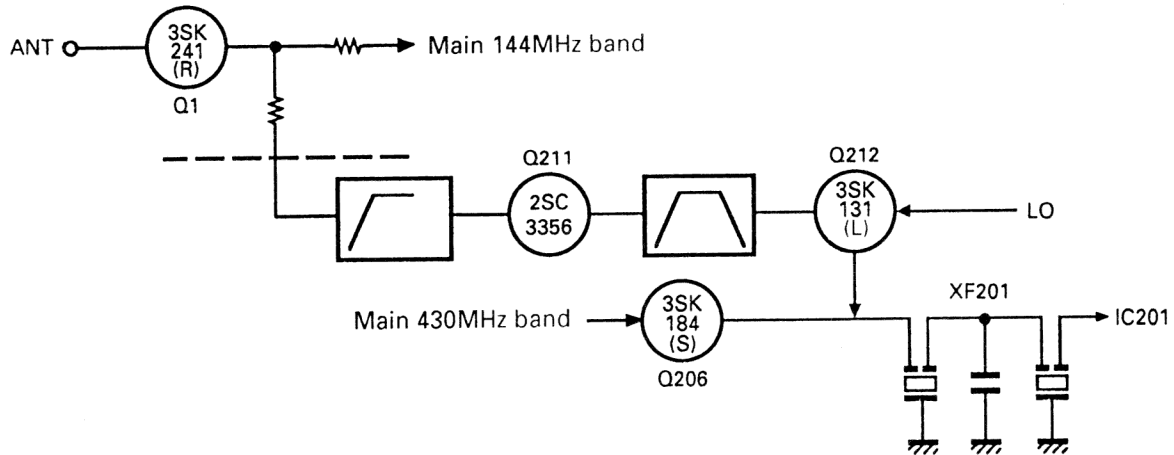

Fig. 2 144MHz band sub receive circuit block diagram

430MHz Band Sub Receive Circuit

The 144MHz unit can receive 430MHz band signals. The received signal from the antenna passes through a transmission/reception selection diode switch in the final section of the 430MHz unit. The signal then passes through an antenna matching coil, and is amplified by a GaAs (gallium arsenide) field-effect transistor (Q201). The amplified receive signal passes through a divider, and is amplified by IC3 (high frequency wide-band am-

plifier) of the 144MHz unit. The unwanted signal components are removed by a band-pass filter. The resulting signal goes to the first mixer, is mixed with the first local oscillator signal from the PLL circuit, and so converted to the first intermediate frequency of 45.05MHz. The subsequent receive-operation is the same as for the 144MHz band.

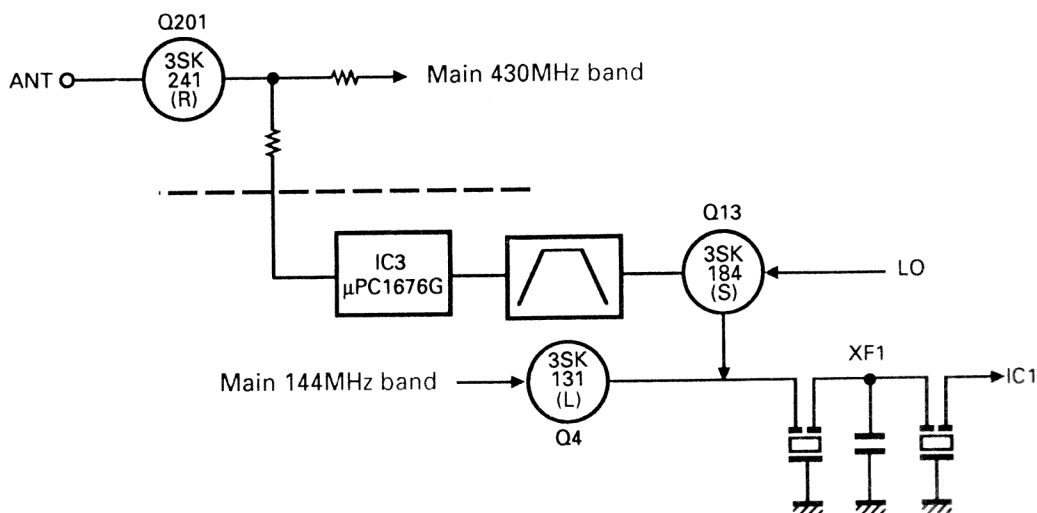

Fig. 3 430MHz band sub receive circuit block diagram

CIRCUIT DESCRIPTION

Squelch Circuit

The panel unit microprocessor reads the angle of rotation of the squelch VR, and converts it to a 6 bit digital value. The panel unit microprocessor transfers the data to the control unit microprocessor, which in turn transfers the data to IC5 (IC205) : XRU4094BF.

The data is converted to analog by analog switch IC4 (IC204) : XRU4066BF according to the output from IC5 (IC205).

The ICs in parentheses are used in the 430MHz band unit.

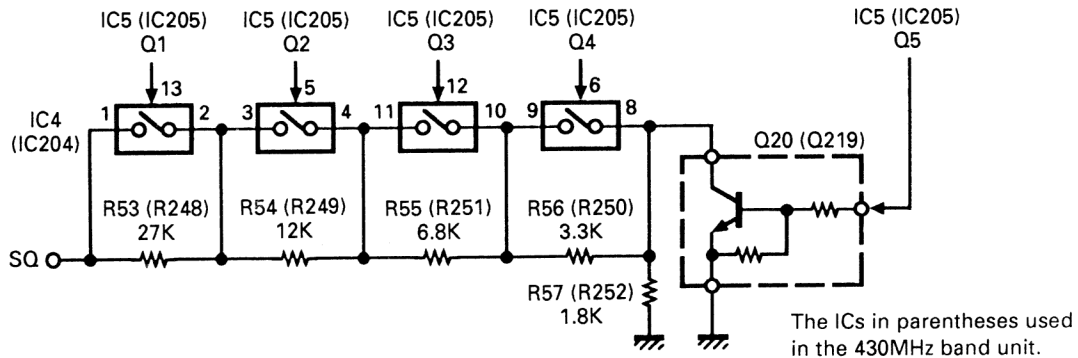

Fig. 4 Squelch circuit

144MHz Band Shift Register Circuit

The ESV1, ESV2, CKV, and DTV serial data from the control unit is sent to IC5, 8 (XRU4094BF) to perform the control operations outlined in the following table.

• IC5 control

Pin No.	Name	Function
1	Strobe	Enable input (ESV2)
2	Data	Serial data input (DTV)
3	Clock	Clock input (CKV)
4	Q1	Squelch level adjustment bit 4. "L" : Resistor present, "H" : Resistor absent
5	Q2	Squelch level adjustment bit 3. "L" : Resistor present, "H" : Resistor absent
6	Q3	Squelch level adjustment bit 2. "L" : Resistor present, "H" : Resistor absent
7	Q4	Squelch level adjustment bit 1. "L" : Resistor present, "H" : Resistor absent
8	Vss	GND.
9	Qs	
10	Q's	
11	Q8	
12	Q7	AIP switching. Low: AIP off
13	Q6	AM gain limit. Low: Low input
14	Q5	Squelch level adjustment bit 0. "L" : Resistor present, "H" : Resistor absent
15	QE	8V
16	VDD	8V

• IC8 control

Pin No.	Name	Function
1	Strobe	Enable input (ESV1).
2	Data	Serial data input (DTV).
3	Clock	Clock input (CKV).
4	Q1	TX/RX selection. TX : "L"
5	Q2	TX power selection. MID and LOW power : "L", HI power : "H"
6	Q3	TX power selection. HI and LOW power : "L", MID power : "H"
7	Q4	
8	Vss	GND.
9	Qs	
10	Q's	
11	Q8	Receiving power switching. VHF band main reception : "L"
12	Q7	
13	Q6	Receiving power switching. UHF band sub reception : "L"
14	Q5	
15	QE	8V
16	VDD	8V

CIRCUIT DESCRIPTION

430MHz Band Shift Register Circuit

The ESU1, ESU2, CKU, and DTU serial data from the control unit is sent to IC205, 206 (RXU4094BF) to perform the control operation outlined in the following table.

• IC205 control

Pin No.	Name	Function
1	Strobe	Enable input (ESU2).
2	Data	Serial data input (DTU).
3	Clock	Clock input (CKU).
4	Q1	Squelch level adjustment bit 4. "L" : Resistor present, "H" : Resistor absent
5	Q2	Squelch level adjustment bit 3. "L" : Resistor present, "H" : Resistor absent
6	Q3	Squelch level adjustment bit 2. "L" : Resistor present, "H" : Resistor absent
7	Q4	Squelch level adjustment bit 1. "L" : Resistor present, "H" : Resistor absent
8	Vss	GND.
9	Qs	
10	Q's	
11	Q8	
12	Q7	AIP switching. AIP OFF : "L"
13	Q6	
14	Q5	Squelch level adjustment bit 0. "L" : Resistor present, "H" : Resistor absent
15	QE	8V
16	VDD	8V

• IC206 control

Pin No.	Name	Function
1	Strobe	Enable input (ESU1).
2	Data	Serial data input (DTU).
3	Clock	Clock input (CKU).
4	Q1	TX/RX selection.
5	Q2	TX power selection. MID and LOW power : "L", HI power : "H"
6	Q3	TX power selection. HI and LOW power : "L", MID power : "H"
7	Q4	Fan control. "H" : during transmission, High for two minutes after TX turns off.
8	Vss	GND.
9	Qs	
10	Q's	
11	Q8	
12	Q7	Receiving power switching UHF band main reception : "L"
13	Q6	
14	Q5	Sub receiving power switching VHF band sub reception : "L"
15	QE	8V
16	VDD	8V

144MHz Band 8T/8R Switching Circuit and Unlock Circuit

A high signal is applied to the base of Q15 and Q19 from the shift register during reception, Q16 is turned on, 8R is output, and Q18 and Q17 are turned off. 8T is not output. 8R is turned off, and 8T is turned on during transmission. The unlock signal is input to Q19 from the PLL unit. When the PLL is unlocked, this signal goes high. So, 8T is not turned on, and transmission does not occur even if a signal arrives from the shift register.

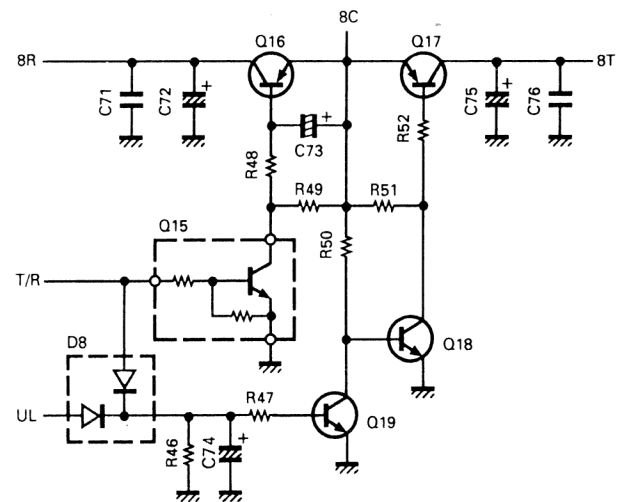

Fig. 5 144MHz band 8T/8R switching circuit and unlock circuit

CIRCUIT DESCRIPTION

430MHz Band 8T/8R Switching Circuit and Unlock Circuit

A high signal is applied to the base of Q215 and Q214 from the shift register during reception, Q216 is turned on, 8R is output, and Q217 and Q218 are turned off. 8T is not output. 8R is turned off, and 8T is turned on during transmission. The unlock signal is input to Q214 from the PLL unit. When the PLL is unlocked, this signal goes high. So, 8T is not turned on, and transmission does not occur even if a signal arrives from the shift register.

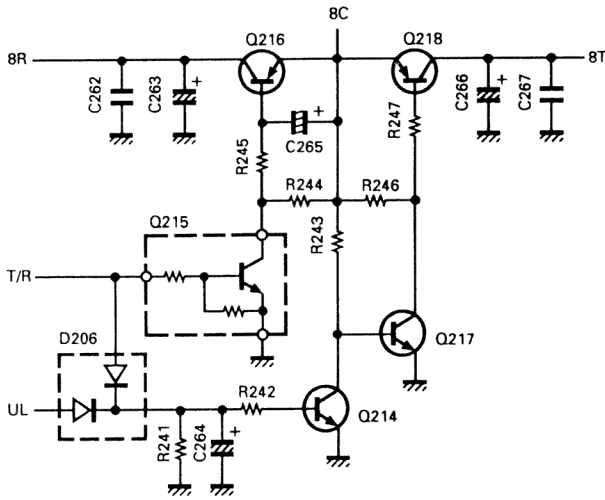

Fig. 6 430MHz band 8T/8R switching circuit and unlock circuit

AF Signal System

• Outline

Detection signals RAV and RAU from the 144MHz and 430MHz units go to the mute and beep circuits of the control unit. The signals pass through the electronic VR, analog signal switching circuit, and speaker switching circuit of the 144MHz unit, and are output to the power amplifier and speaker.

• Beep and mute circuits

To sound the beep when a key is pressed, a pulse is output from P20 of the CPU, mixed with the output through the buffer (Q403) of monitor IC402 (DTMF encoder) for DTSS operation, passed through the beep mute circuit (Q404 and Q405) for each band, mixed with the detection signal for each band, and sent to the electronic VR. The audio mute circuit (Q409 and Q410) for each band works only when the beep sound is output from the CPU.

The signal output from the electronic VR passes through analog switch IC404 and the audio mute circuit (Q411 and Q412), and is output to the speaker switching circuit. The CPU transfers data to the electronic volume in the same way as for the TM-942.

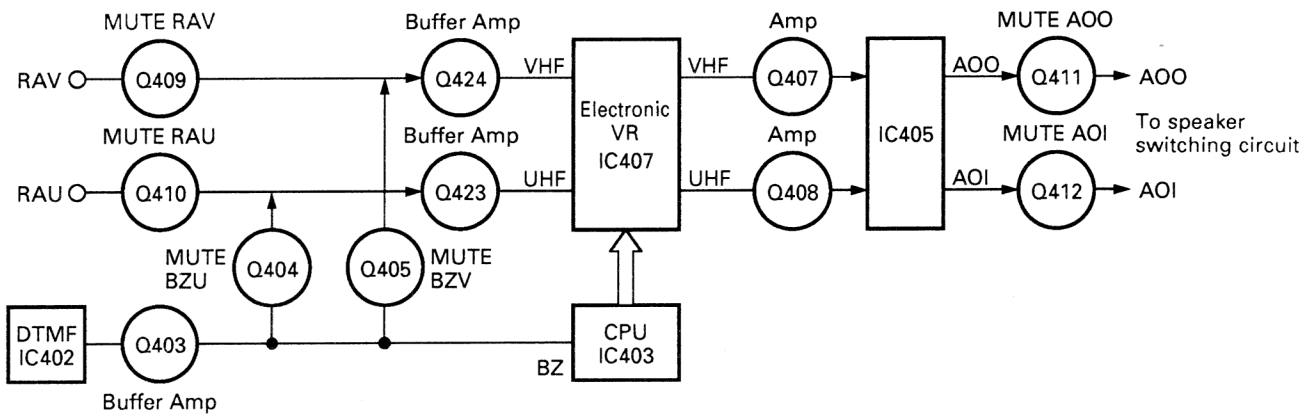

Fig. 7 AF signal system block diagram

CIRCUIT DESCRIPTION

Digital Control Unit

• Outline

The digital control unit controls functions with a single microprocessor (CPU). It consists of the tone output circuit, DTMF encode/decode circuit, electronic VR circuit, and analog signal switching circuit.

It contains the reset and backup circuits, microphone amplifier circuit, and microphone key input circuit.

Speaker switching circuit

The 144MHz unit has two speaker jacks, J1 and J2. AF signals can be output to various combinations of speakers, including the internal speaker.

If no external speaker is connected to J1, pins 10 and 11 of IC7 go low, and AF signals AOO and AOI from the control unit are added. The resulting signal goes to power amplifier IC6.

If an external speaker is connected to J1, pins 10 and 11 of IC7 go high, and AOO and AOI are input to IC6 separately.

Combinations of AF signals are listed below.

	AOO	AOI
Internal speaker only	Internal speaker	
External speaker (J2)	External speaker	
External speaker (J1)	Internal speaker	External speaker
Internal speakers (2)	External speaker	Internal speaker

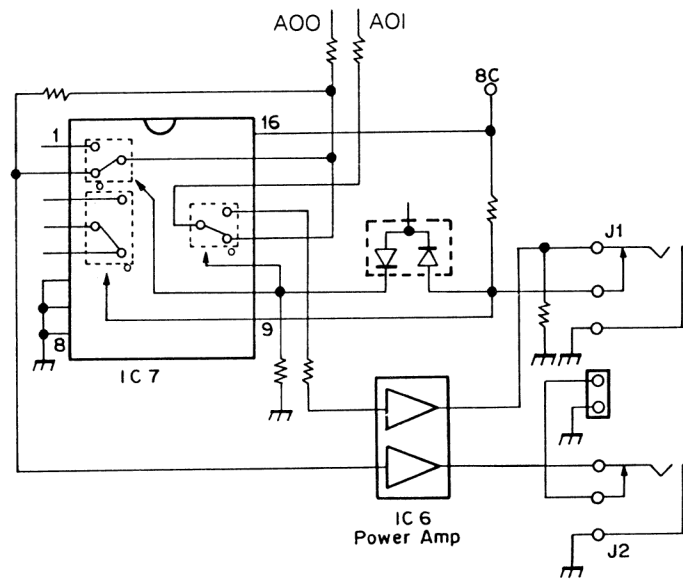

Fig. 8 Speaker switching circuit

Data Communication Circuit in the Panel Control Unit

Figure 9 shows the data communication circuit in the panel control unit. SO is serial data out and SI is serial data in. There is an inverter between them to protect the microprocessor ports.

Data communication is based on start-stop synchronization, and the transmission speed is 31250 bps. The microcomputer in the control unit checks connection every half second. If the check fails twice or the panel section is disconnected for more than one second, the power is turned off.

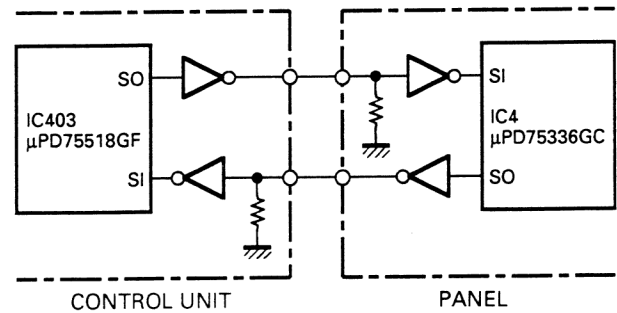

Fig. 9 Data communication circuit in the panel control unit

CIRCUIT DESCRIPTION

Tone Output Circuit

The signal is input to CP401 (ladder resistor) from P41 to P43, and P50 to P53 of the CPU, and converted from digital to analog to produce 38 signals of 67.0 to 250.3Hz. Figure 10 shows the internal configuration of CP401.

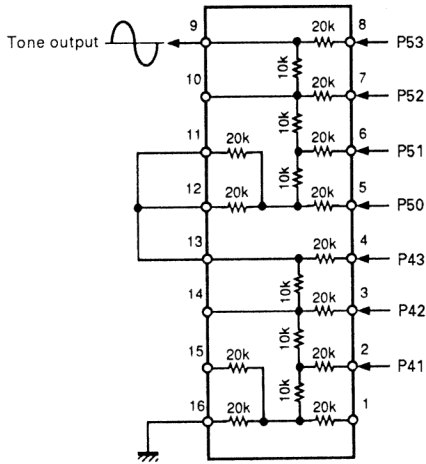

Fig. 10 Internal configuration of CP401

DTMF Encode/Decode Circuit

• DTMF encode/decode circuit

Data is transmitted to IC402 (TC35219F) from P90 to P93, and P72 to P73 of the CPU, and a DTMF signal is output from IC402.

• DTMF decode circuit

When the received signal or a signal from the DTMF microphone (option) enters IC401 (LC7387M) and an effective tone pair is detected, STD goes high, is input to P12 of the CPU, and serial data from IC401 is read into P61 according to the serial clock from P22.

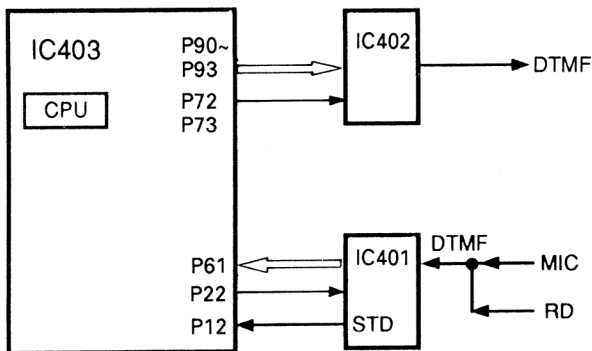

Fig. 11 DTMF encode/decode circuit

Analog Signal Switching Circuit

IC405 switches the audio signal and DTMF decoder input MIC/RD, and IC406 switches between RDV and RDU of MIC, DTMF, and CTCSS.

• Audio signal switching

Switches the VHF AF signal and UHF AF signal from the electronic VR to AOI or AOO.

• DTMF MIC/RD switching

Switches the DTMF decoder IC input to the DTMF signal in the detection signal or the DTMF signal from the microphone.

• MIC RD V/U switching

Switches the signal output from microphone pin RD to RDV or RDU.

• DTMF RD V/U switching

Switches the input signal to the DTMF decoder IC to RDV or RDU. The signal passes through this circuit and the DTMF MIC/RD switching circuit, and goes to the DTMF decoder IC.

The signal is switched to RDV or RDU when a busy sense signal (SC) enters the CPU and DTSS and PAG are on for the band. If busy sense signals enter the CPU for both bands at the same time, the last detected band is used.

• CTCSS RD V/U switching

Switches the signal to the CTCSS unit (TSU-8 option) to RDV or RDU. The signal is switched to RDV or RDU when a busy sense signal (SC) enters the CPU and CTSCC is on for the band. If busy sense signals enter the CPU for both bands, the circuit is switched in 500msec intervals.

P101 (Audio signal switching)	H : AOO=VHF AF, AOI=UHF AF L : AOO=UHF AF, AOI=VHF AF
P100 (DTMF MIC/RD switching)	H : DTMF signal in the detection signal L : DTMF signal from microphone
P110 (MIC RD V/U switching)	H : RDV L : RDU
P103 (DTMF RD V/U switching)	H : RDV L : RDU
P102 (CTCSS RD V/U switching)	H : RDV L : RDU

CIRCUIT DESCRIPTION

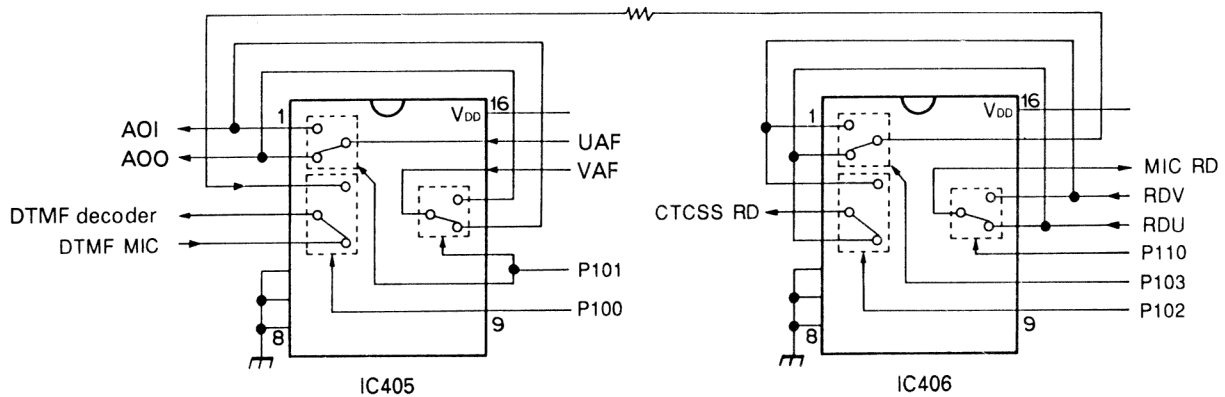

Fig. 12 Analog signal switching circuit

DATA Connector and Peripheral Circuits

The data communication connector (J402) is on the front panel to control transmission, data input/output, and squelch signals. There are two data communication modes: 9600 bps mode and conventional 1200 bps mode.

The 9600 bps mode is mainly used for 9600 bps GMSK and G3RUH packet communication. Unlike general 1200 bps AFSK, this high-speed modulation system effects frequency modulation by passing digital base band signals (square waves) through a filter for bandwidth limiting. This signal is similar to a digitally modulated 4800Hz signal (nearly sine wave because it is passed through a filter) in 9600 bps GMSK mode, and sounds like noise. There are GMSK and G3RUH systems according to the type of bandwidth limiting filter.

• Transmit signals

The transmission modulation signal enters through PKD. The path to the modulator when 9600 bps mode is on is different from that when it is off. The path when the DATA connector PKS is low is different from the path when PTT is low. Figure 13 lists paths (A), (B), and (C), and table 4 lists modulation input levels.

When 9600 bps mode is on, the frequency deviation changes according to the input signal level. A protection circuit is provided to inhibit transmission when the level reaches 4Vp-p.

The input PKD signal is partially detected by D411, and smoothed by C470 and R528. If the signal level reaches 4Vp-p, Q420 turns on and the Q422 output goes low. At the same time, the PKD signal connected to MO by IC411 is disconnected, Q421 turns off, and the PTT control signal goes high to stop transmission. PKS transmission is inhibited if the input reaches 4Vp-p.

Pin No.	Pin name	Specification	
1	PKD	bps selection	
		1200 bps	9600 bps
		Modulation input	40mVp-p 2Vp-p
	Frequency deviation	3±0.5kHz 2±0.5kHz	
4	PR9	Output level : 500mVp-p/10kΩ Always input during reception	
5	PR1	Output level : 300mVp-p/10kΩ Not output if squelch is closed.	

Table 4 DATA connector input/output level

• Receive signal

PR9 is a receive output for high-speed data communication (9600 bps), and the FM detection circuit output (DET signal) is output through the Q402 buffer amplifier. This signal is always output regardless of whether the squelch is open or closed.

PR1 is a receive output for general communication (1200 bps), and like PR9, the FM detection circuit output (DET signal) is output through the Q418 buffer amplifier. PR1 is squelch-controlled by IC404.

CIRCUIT DESCRIPTION

• Squelch signal output circuit

The squelch signal is input to TNC to prevent collision during packet communication. It is a digital transistor output pulled up by 5V and has the logic shown on the right.

SQC pin output (J402 pin 6)	Low: SQ close High: SQ busy
--------------------------------	--------------------------------

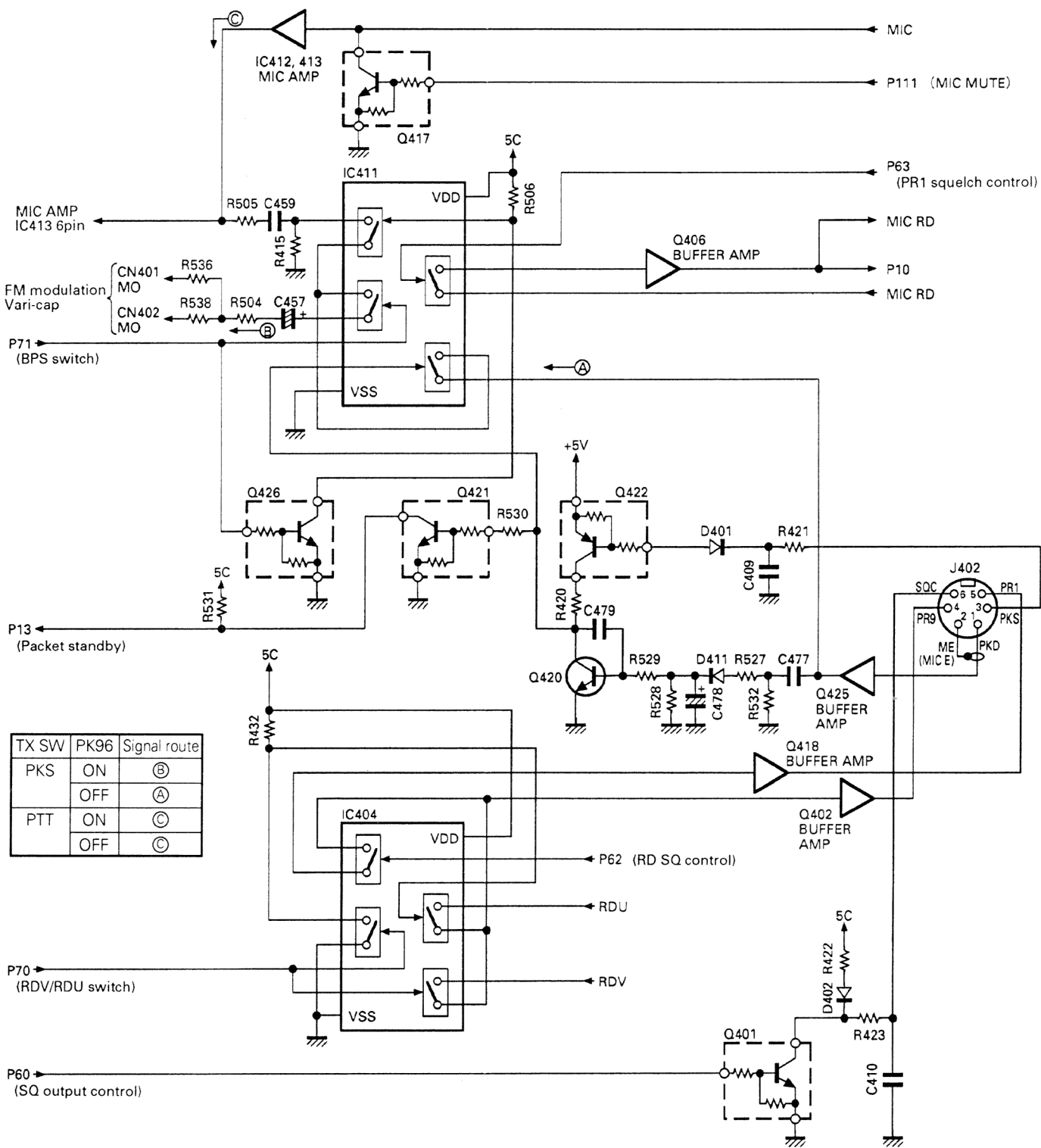

Fig. 13 DATA connector and peripheral circuits

CIRCUIT DESCRIPTION

Reset and Backup Circuits

When the power supply is disconnected, the voltage drop of the 13.8V line is detected, and INT4 of the CPU goes high. The CPU enters the backup mode.

When the power supply is disconnected and the voltage drop of the 5V line is detected, BA1 (lithium battery), which has been charged through D19,

discharges to provide backup power for the CPU through D18.

When the power supply is connected, a low level pulse of about 3msec duration is output by the reset circuit. This pulse goes to RESET of the CPU for power-on reset.

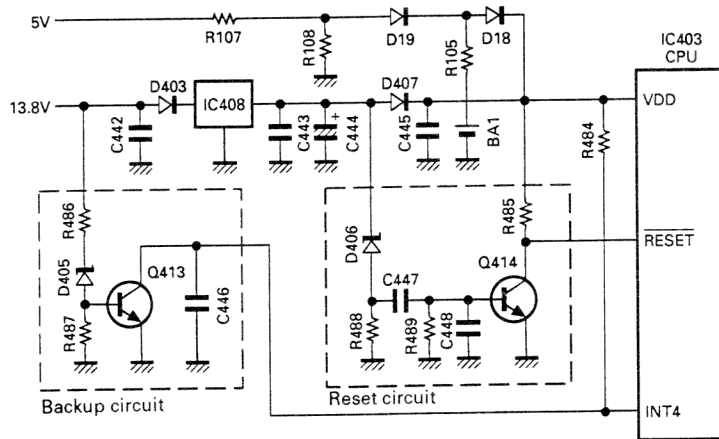

Fig. 14 Reset and backup circuits

Microphone Amplifier Circuit

The audio signal from the microphone goes to three operational amplifiers. These amplifiers constitute a pre-emphasis circuit, amplifier, limiter, and splatter circuit that eliminates unwanted high frequency components.

The modulator circuit directly modulates the frequency of the VCO for both the 144 and 430MHz bands by means of a vari-cap diode.

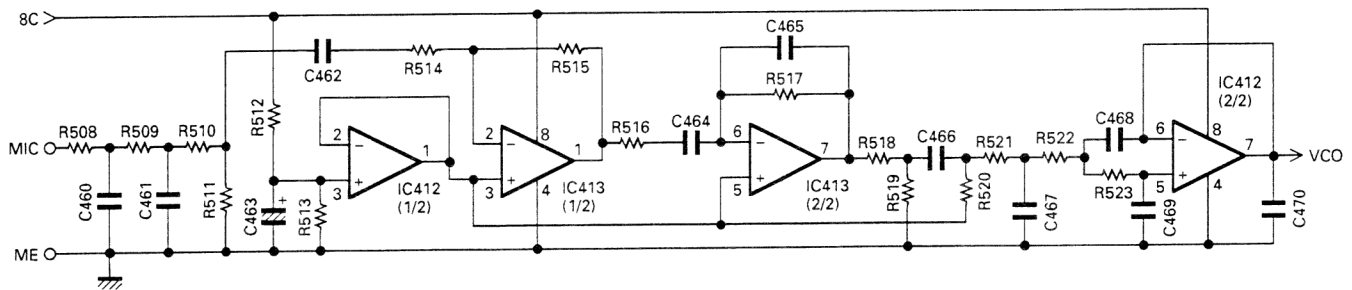

Fig. 15 Microphone amplifier circuit

CIRCUIT DESCRIPTION

Microphone Key Input

The microphone UP, DOWN, and function keys are connected to the analog input of the CPU, and each function is activated according to the voltage applied when a key is pressed.

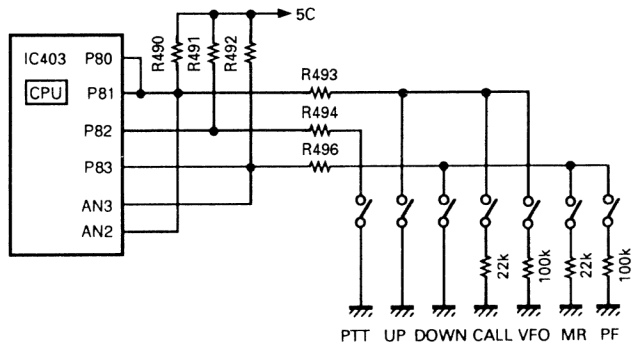

Fig. 16 Microphone key input

Panel Unit (LCD Assy)

(B38-0708-25 : M4 type)

B38-0709-25 : Except M4 type)

• Outline

The panel unit has a microcomputer to control serial communication with the control unit of the main unit, the display circuit, memory, and dimmer circuit. The keys and key rotary encoder input signals directly to the microcomputer.

Dimmer Circuit

The dimmer circuit can change the brightness of the lamp in four steps, and turn the lamp off. Q3 amplifies the error of the stabilized power supply using a 5V reference voltage. The output voltage can be controlled in four steps by grounding a combination of the BP2 and BP3 ports of the microprocessor. If the impedance of BP1, connected to the emitter of Q2, is made high, Q2 is turned off. No lamp voltage is output, and the lamp goes off.

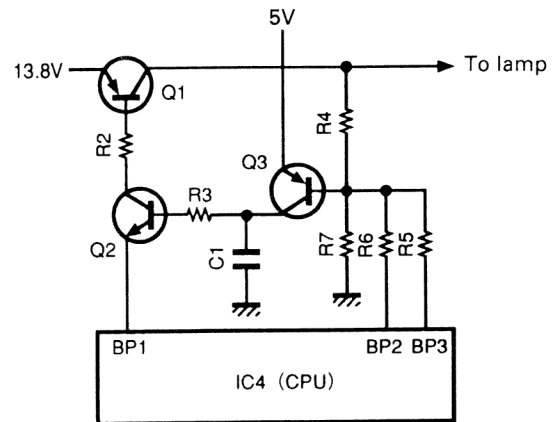

Fig. 17 Dimmer circuit

Reset Circuit

When the power supply is connected, the IC1 (L78LR05B-FA) output (pin 5) becomes 5V, and after about 100msec, RESET (pin 4) goes high. The signal is input to the RESET pin of the CPU (IC4) to reset it.

Key and Rotary Encoder Input Circuit

Each panel key signal is input from its own port. The VFO, and PM keys are pulled up by external resistors (the PSW key is pulled down), and the other keys are pulled up by software. The rotary encoder inputs signals directly to the microcomputer.

CIRCUIT DESCRIPTION

Display Circuit

The display circuit consists of the microcomputer, LCD driver and peripheral circuits, and LCD. The LCD is driven dynamically with a half-duty cycle. Part of the display is controlled by the driver (IC4) in the microcomputer, and part is controlled by the LCD driver (IC6 and IC7), as shown in Figure 18. Data is transferred serially to the LCD driver from P40 to P43 of the microcomputer.

Memory

Memory channel data is stored in IC5 (non-volatile memory). Data is written and read as serial data through P31 and P32.

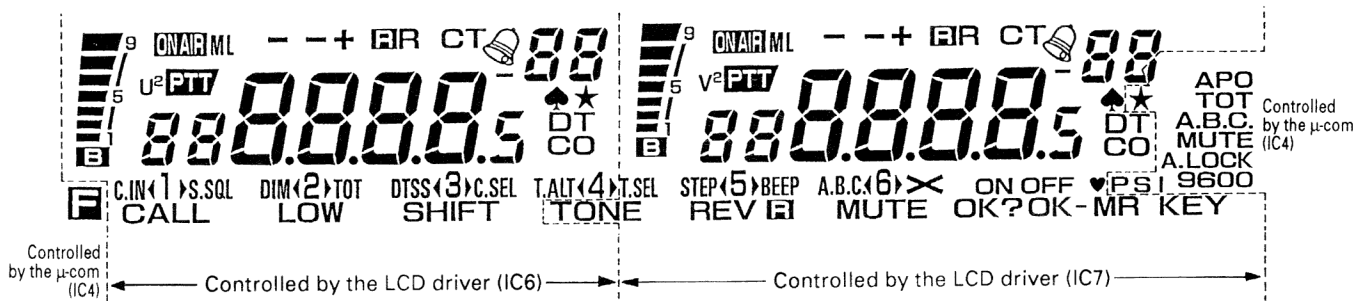

Fig. 18 Display LCD (Except M4 type)

144MHz Band PLL Synthesizer

The VCO and PLL circuits comprise a hybrid integrated circuit housed in a solid shielded case. X2 (12.8MHz) is generated by the PLL IC (M56760FP) in the HIC, and is divided to produce a 5 or 6.25kHz reference frequency. Part of the 12.8MHz output is passed through the buffer amplifier, and goes to the 430MHz unit.

Comparison frequencies are produced by dividing X2 to correspond to the 5, 10, 15, 20, 12.5, and 25kHz

channel steps. When VHF band signals are received, 163.05 to 219.045MHz (K,P), 189.05 to 193.045MHz (M), 189.05 to 191.045MHz (E) is generated, and when VHF band signals are transmitted, 144.00 to 147.995MHz (K,P,M), 144.00 to 145.995MHz (E) is generated. When UHF sub band signals are received, a lock is established at twice the VCO oscillation frequency to produce 364.95 to 424.945MHz (K,P), 384.95 to 394.945MHz (M,E).

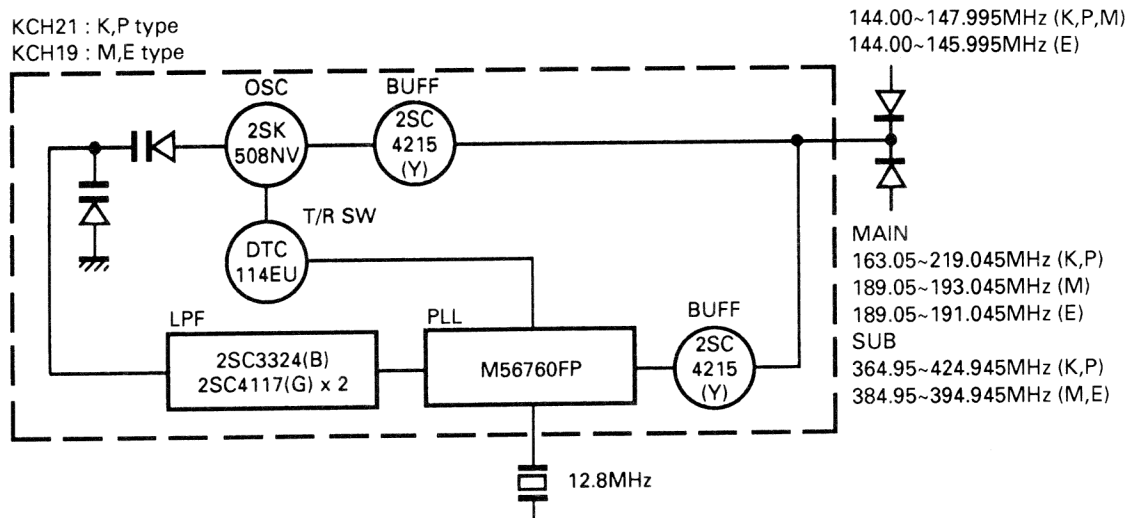

Fig. 19 144MHz band PLL block diagram

CIRCUIT DESCRIPTION

430MHz Band PLL Synthesizer

The VCO and PLL circuits comprise a hybrid integrated circuit housed in a solid shielded case. Comparison frequencies are produced by dividing a 12.8MHz reference frequency from the 144MHz band unit to correspond to the 5, 10, 15, 20, 12.5, and 25kHz channel steps.

When UHF band signals are received, 351.475 to 411.47MHz (K,P), 371.475 to 381.47MHz (M,E) is

generated, and when UHF-band signals are transmitted, 438.00 to 449.995MHz (K,P), 430.00 to 439.995MHz (M,E) is generated. When sub-VHF-band signals are received, the main VCO in the PLL unit stops and the sub-VCO for VHF operates to produce 188.525 to 232.52MHz (K,P), 202.525 to 206.52MHz (M), 202.525 to 204.52MHz (E).

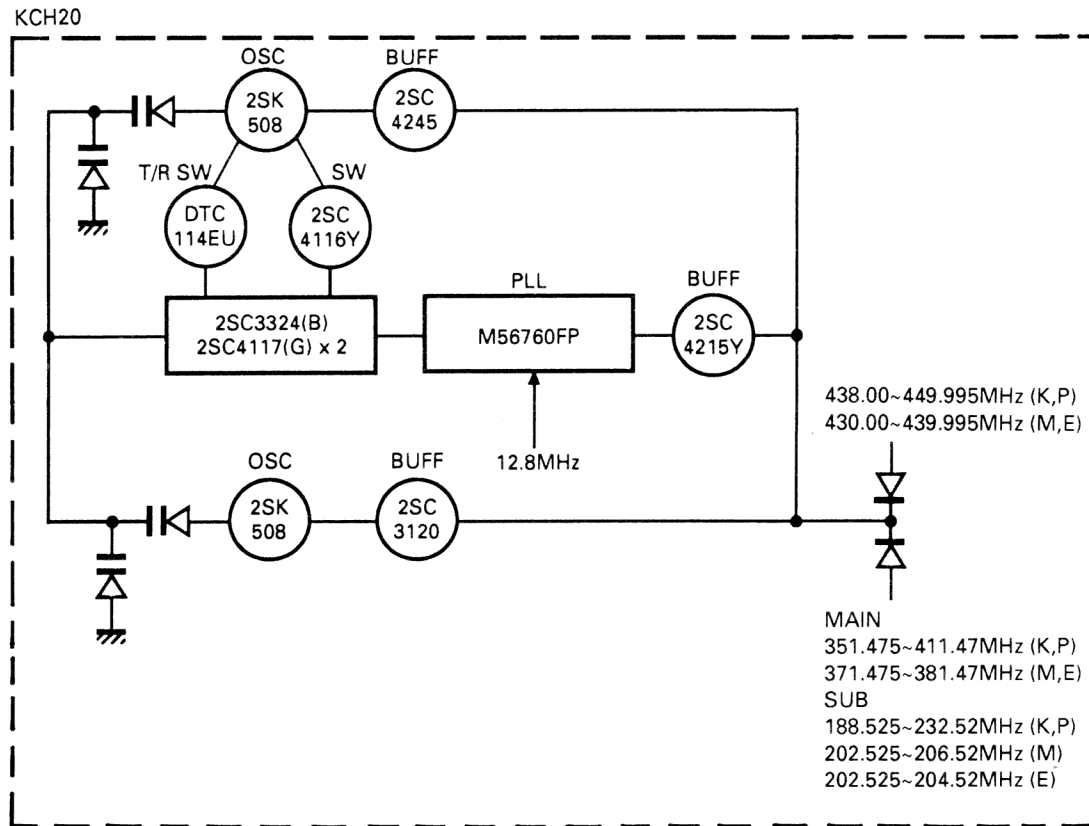

Fig. 20 430MHz band PLL block diagram

CIRCUIT DESCRIPTION

I/O Port Specifications

• 75336GC-075-3B9 (LCD ASSY : IC4)

Pin No.	μ-com port	Port name	I/O	Pull up	Back up	Description	Circuit pin name
1~4	S31/BP7~S28/BP4		O			Not used.	
5, 6	S27/BP3, S26/BP2	P DIM2, P DIM1	O			Dimmer. 1,2 = 1,0 : D3 1,1 : D4 0,0 : D1 0,1 : D2	
7	S25/BP1	P LAMP	O			Lamp. 0 : ON, 1 : OFF	
8	S24/BP0		O			Not used.	
9~13	S23~S19	S23~S19	O			Not used.	
14~20	S18~S12	S18~S12	O			LCD segment driver.	
21, 22	COM0, COM1	COM0, COM1	O			LCD common driver.	
23, 24	COM2, COM3		O			Not used.	
25	BIAS	BIAS	O			External division resistor cutting output pin.	
26~28	VLC0~VLC2	VLC0~VLC2	I			LCD drive power pin.	
29	P40	P LCDCE1	O	•		LCD driver chip enable 1. NJU6432	CE1
30	P41	P LCDCK	O	•		LCD driver clock. NJU6432	CLK
31	P42	P LCDDT	O	•		LCD driver data. NJU6432	DN
32	P43	P LCDCE2	O	•		LCD driver chip enable 2. NJU6432	CE2
33	Vss	Vss	-			GND.	
34	P50	P LEDV	O			Control display LED (VHF). 0 : ON, 1 : OFF	
35	P51	P LEDU	O			Control display LED (UHF). 0 : ON, 1 : OFF	
36	P52	P LCDINH	O	•		LCD display all on. NJU6432	INH
37	P53		O			Not used.	
38	INT4/P00	P BCHK	I			+B check. 0 : Power not connected, 1 : Power connected	
39	SCK/P01		I	○		Not used.	
40	SO/SB0/P02	P SO	O	○		Common microprocessor. SI	
41	SI/SB1/P03	P SI	I	○		Common microprocessor. SO	
42	INT0/P10	P ENCK	I	•		Encoder clock.	
43	INT1/P11	P INT1	I			Connect to P SI.	
44	INT2/P12	P ENCDT	I	•		Encoder data.	
45	TIO/P13	P PS	I			Power switch (non-locking).	S4
46	PTO0/P20	P KEY12	I	○		Band select VHF.	SWA
47	P21	P KEY13	I	○		Band select UHF.	SWB
48	PCL/P22		I	○		Not used.	
49	BUZ/P23		I	○		Not used.	
50	LCDCL/P30	P S5	O			S5 switching.	
51	SYNC/P31	P EPSDA	I/O	•		EEPROM. SDA	SDA
52	P32	P EPSCL	O	■		EEPROM. SCL	SCL
53	P33		O			Not used.	
54	P80	P KEY3	I	○		MHz key.	ESW
55	P81	P KEY2	I	○		MR key.	S2
56	P82	P KEY1	I	•		VFO key.	S1
57	P83	P KEY14	I	•		PM key.	S3
58, 59	AN0, AN1		I			Not used.	
60	AN2	P SQLV	I			VHF band squelch input.	
61	AN3	P VOLV	I			VHF band volume input.	
62	AN4	P SQLU	I			UHF band squelch input.	
63	AN5	P VOLU	I			UHF band volume input.	
64	AVss	AVss	-			A/D converter reference GND.	
65	AVref	AVref	I			A/D converter reference voltage.	
66	VDD	VDD	-			Power supply (Microprocessor).	

CIRCUIT DESCRIPTION

Pin No.	μ-com port	Port name	I/O	Pull up	Back up	Description	Circuit pin name
67	XT1		I			Not used.	
68	XT2		-			Not used.	
69	VPP	VPP	-			GND.	
70, 71	X1, X2	X1, X2	I			Clock oscillator connection (4.192MHz).	
72	RESET	RESET	I			Reset input.	
73	KR0/P60	P KEY11	I	○		CONT SEL key.	S12
74	KR1/P61	P KEY10	I	○		F key.	S11
75	KR2/P62	P KEY9	I	○		MUTE key.	S10
76	KR3/P63	P KEY8	I	○		REV key.	S9
77	KR4/P70	P KEY7	I	○		TONE key.	S8
78	KR5/P71	P KEY6	I	○		BELL key.	S7
79	KR6/P72	P KEY5	I	○		LOW key.	S6
80	KR7/P73	P KEY4	I	○		CALL key.	S5

Δ : Pulled up by software during checking only

○ : Always pulled up by software

● : Always pulled up by hardware

■ : Always pulled down by hardware

CIRCUIT DESCRIPTION

• 75518GF-18X-3B9 (TX-RX UNIT : IC403)

Pin No.	μ-com port	Port name	I/O	Pull up	Back up	Description	Circuit pin name
1	AN0	P SMV	I			VHF-band signal-strength meter input.	SMV
2	AVREF	AVREF	I			Reference voltage for A/D converter.	
3, 4	VDD	VDD	I			Power for microcomputer.	
5	P113	P MUTEIN	O		I	Internal speaker mute. 0 : OFF, 1 : ON (Off when a beep is output)	
6	P112	P MUTEEX	O		I	External speaker mute. 0 : OFF, 1 : ON (Off when a beep is output)	
7	P111	P MMUTE	O		I	Microphone mute. 0 : OFF, 1 : ON	
8	P110	P MICRD	O		I	Microphone RD switching. 0 : UHF, 1 : VHF	
9	P103	P DTMFRD	O		I	DTMF RD switching. 0 : UHF, 1 : VHF	
10	P102	P CTCSRD	O		I	CTCSS RD switching. 0 : UHF, 1 : VHF	
11	P101	P SP	O		I	Speaker switching. 0 : Internal speaker for VHF, 1 : Internal speaker for UHF	
12	P100	P DTSEL	O		I	DTMF input switching. 0 : Microphone, 1 : Detection output	
13~16	P93~P90	PB3/PD4 ~PB0/PD1	I O		I	Destination input b3 to b0 (at power on). DTMF encoder data (D4~D1). TC35219	D4~D1
17	SI1/P83	P DOWN	I	●	I	Microphone DOWN.	
18	SO1/P82	P PTT	I	●	I	Microphone PTT.	
19	SCK1/P81	P UP	I	●	I	Microphone UP.	
20	PPO/P80		I		I	Connected to SCK1 (for clock for cloning).	
21	KR7/P73	P TDPC	O		I	DTMF encoder (TD/PC). TC35219	TD/PC
22	KR6/P72	P C2	O		I	Single tone (1633Hz). 0 : Single tone, 1 : Dual tone (CONT2) TC35219	CONT2
23	KR5/P71	P PBS	O	●	I	bps selection. 0 : 1200 bps, 1 : 9600 bps	PBS
24	KR4/P70	P PBRD	O	●	I	PTT band RD control. 0 : UHF, 1 : VHF	PBRD
25	KR3/P63	P MRSQ	O		I	Microphone RD SQ control. 0 : SQ close, 1 : SQ busy	MRSQ
26	KR2/P62	P PRD	O		I	RD SQ control. 0 : SQ close, 1 : SQ busy	PRD
27	KR1/P61	P SD	I		I	DTMF decoder data (SD). LC7387M	SD
28	KR0/P60	P SQ	I O		I	Display mode setting. 0 : Normal, 1 : Channel display Data communication control. 0 : SQ busy, 1 : SQ close	PSQ
29~32	P53~P50	P TONE	O	●	I	Subtone output bits 7~4.	
34~36	P43~P41	P TONE	O	●	I	Subtone output bits 3~1.	
37	P40	P 1750	O	●	I	1750Hz tone.	
38	P33	P 5C	O		I	5C ON/OFF. 0 : ON, 1 : OFF	
39	P32	P ET	O/I		I	CTCSS unit enable/connection check. 0 : Connected, 1 : Not connected	CTE
40	P31	P ES2U	O		I	Shift register 2 enable. UHF	ESU2
41	P30	P ES1U	O		I	Shift register 1 enable. UHF	ESU1
42	BUZ/P23	P EPU	O		L	PLL enable. UHF	EPU
43	PCL/P22	P CKU	O		L	Shift register/PLL/DTMF clock. UHF	CKU
44	P21	P DTU	O		L	Shift register/PLL data. UHF	DTU
45	PTO0/P20	P BEEP	O		L	Beep output pin (effect sound). "L" when no beep is output.	
46	TI0/P13	P PKS	I		I	Packet standby. 0 : Standby, 1 : Busy	PKS
47	INT2/P12	P STD	I	■	I	DTMF detection (LC7387 STD). 0 : No signal detected, 1 : Signal detected	STD
48	INT1/P11	P CTCSS	I		I	CTCSS detection. 0 : Tone match, 1 : Tone mismatch	SDO
49	INT0/P10	P RD	I		I	Remote control clone connection check. 0 : Not connected, 1 : Connected	
50	SI0/SB1/P03	P SI	I	○		Panel microprocessor. SO	

CIRCUIT DESCRIPTION

Pin No.	μ-com port	Port name	I/O	Pull up	Back up	Description	Circuit pin name
51	SO0/SB0/P02	P SO	O	○		Panel microprocessor. SI	
52	SCK0/P01		I			Not used.	
53	INT4/P00	P VF	I			Power check. 0 : Operating, 1 : Back up	
54	Vss	Vss	-			GND.	
55	XT1		I			Not used.	
56, 57	XT2, IC		-			Not used.	
58, 59	X1, X2	X1, X2	I			Clock oscillator connection (4.192MHz).	
60	RESET	RESET	I			Reset input.	
61	P143	P DTV	O	●	I	Shift register/PLL/Electronic volume/CTCSS data. VHF	DTV
62	P142	P CKV	O	●	I	Shift register/PLL/Electronic volume/CTCSS clock. VHF	CKV
63	P141	P EPV	O	●	I	PLL enable. VHF	EPV
64	P140	P ES1V	O	●	I	Shift register 1 enable. VHF	ESV1
65	P133	P ES2V	O	●	I	Shift register 2 enable. VHF	ESV2
66	P132	P PSW	O	●	I	Power switch. 0 : Power OFF, 1 : Power ON	PSW
67	P131	P RDMUTE	O	●	I	RD mute. 0 : Transmission with repeater, 1 : ON	
68	P130	P VOLEN	O	●	I	Electronic volume enable. L : UHF, R : VHF	CS
69	P123	P BPMUTU	O	●	I	Beep mute (UHF). 0 : OFF, 1 : ON	
70	P122	P BPMUTV	O	●	I	Beep mute (VHF). 0 : OFF, 1 : ON	
71	P121	P BPAFMU	O	●	I	Beep AF mute (UHF). 0 : OFF, 1 : ON	
72	P120	P BPAFMV	O	●	I	Beep AF mute (VHF). 0 : OFF, 1 : ON	
74	AN7/P153	P SCU	I			SC input (UHF). 0 : Busy, 1 : Close	SCU
75	AN6/P152	P SCV	I			SC input (VHF). 0 : Busy, 1 : Close	SCV
76	AN5/P151						AGC
77	AN4/P150						RPT
78	AN3	P DNAN	I			DOWN, MR, RF.	
79	AN2	P UPAN	I			UP, CALL, VFO.	
80	AN1	P SMU	I			UHF band S-meter input.	SMU

Δ : Pulled up by software during checking only

● : Always pulled up by hardware

○ : Always pulled up by software

■ : Always pulled down by hardware

CIRCUIT DESCRIPTION

• Shift register XRU4094BF (TX-RX UNIT : IC8) : VHF

S.Reg port	Pin No.	Port data name	Save	Back up	Function	Remarks
Q1	4	PD TXRX			0 : Transmission, 1 : Reception	TX/RX
Q2	5	PD HI			0 : MID, LOW power, 1 : HI power	HI
Q3	6	PD MID			0 : HI, LOW power, 1 : MID power	MID
Q4	7	PD 11R				11R
Q5	14	PD 12R				12R
Q6	13	PD 43R			430MHz band power supply voltage switching.	43R
Q7	12	PD AM			AM/FM switching. 0 : AM, 1 : FM	
Q8	11	PD 14R			144MHz band power supply voltage switching.	14R

• Shift register XRU4094BF (TX-RX UNIT : IC5) : VHF squelch

S.Reg port	Pin No.	Port data name	Save	Back up	Function	Remarks
Q1	4	PD SQV4			SQL bit 4.	
Q2	5	PD SQV3			SQL bit 3.	
Q3	6	PD SQV2			SQL bit 2.	
Q4	7	PD SQV1			SQL bit 1.	
Q5	14	PD SQV0			SQL bit 0.	
Q6	13	PD AM			AM gain limit. 0 : Normal, 1 : Limit	
Q7	12	PD IMV			IM selection. 0 : IM OFF, 1 : IM ON	
Q8	11	PD			-	

• Shift register XRU4094BF (TX-RX UNIT : IC206) : UHF

S.Reg port	Pin No.	Port data name	Save	Back up	Function	Remarks
Q1	4	PD TXRX			0 : Transmission, 1 : Reception	TX/RX
Q2	5	PD HI			0 : MID, LOW power, 1 : HI power	HI
Q3	6	PD MID			0 : HI, LOW power, 1 : MID power	MID
Q4	7	PD FAN			0 : FAN OFF, 1 : FAN ON	
Q5	14	PD 14R			144MHz band power supply voltage switching.	14R
Q6	13	PD 80R				80R
Q7	12	PD 43R			430MHz band power supply voltage switching.	43R
Q8	11	PD 36R				36R

• Shift register XRU4094BF (TX-RX UNIT : IC205) : UHF squelch

S.Reg port	Pin No.	Port data name	Save	Back up	Function	Remarks
Q1	4	PD SQU4			SQL bit 4.	
Q2	5	PD SQU3			SQL bit 3.	
Q3	6	PD SQU2			SQL bit 2.	
Q4	7	PD SQU1			SQL bit 1.	
Q5	14	PD SQU0			SQL bit 0.	
Q6	13	PD			-	
Q7	12	PD IMU			AIP selection. 0 : AIP OFF, 1 : AIP ON	
Q8	11	PD			-	

SEMICONDUCTOR DATA

144MHz Band PLL : KCH19/KCH21 (TX-RX Unit A/4 IC9)

• Schematic diagram

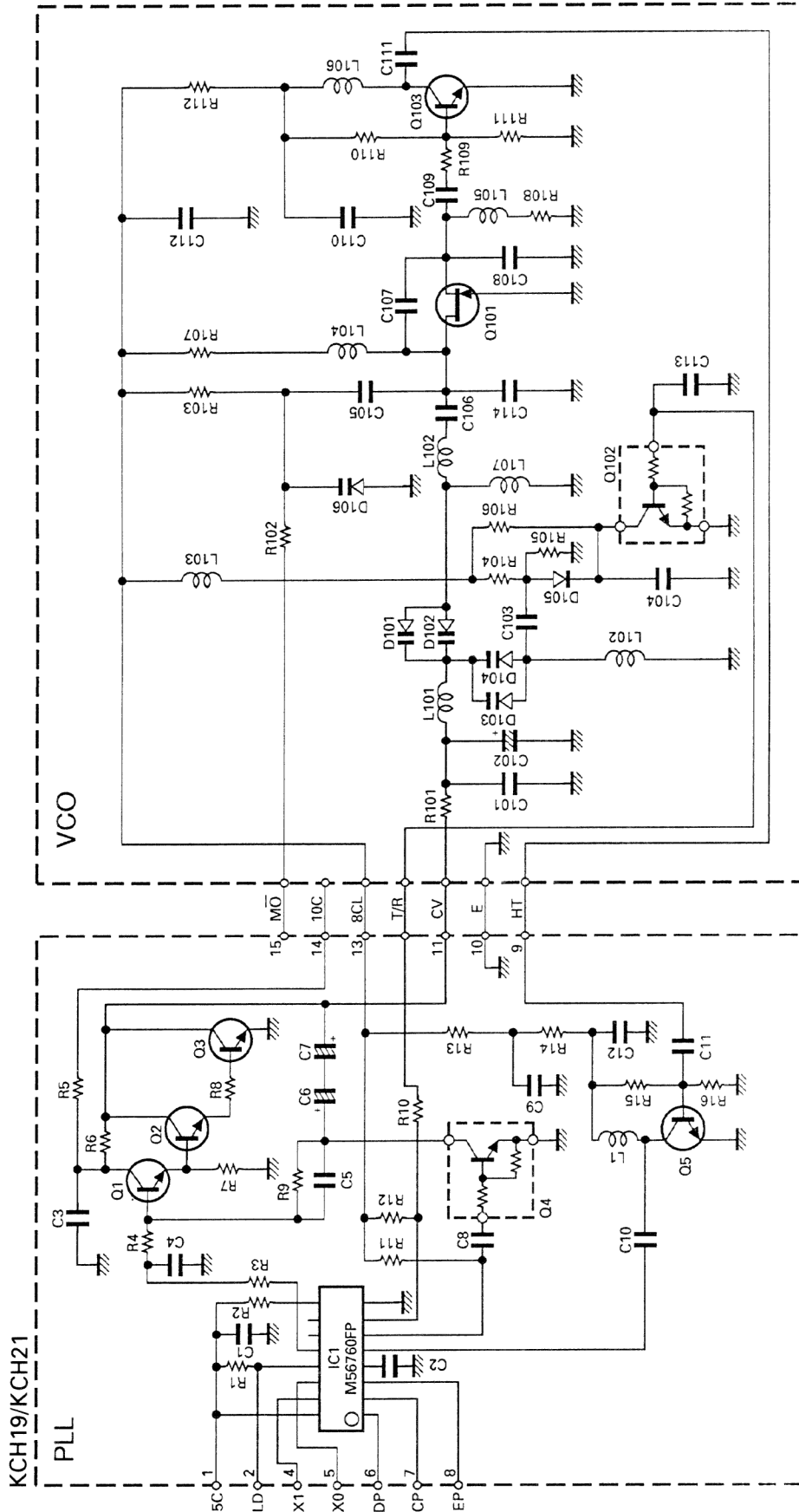

SEMICONDUCTOR DATA

430MHz Band PLL (With Sub-VCO) : KCH20 (TX-RX Unit B/4 IC207)

• Schematic diagram

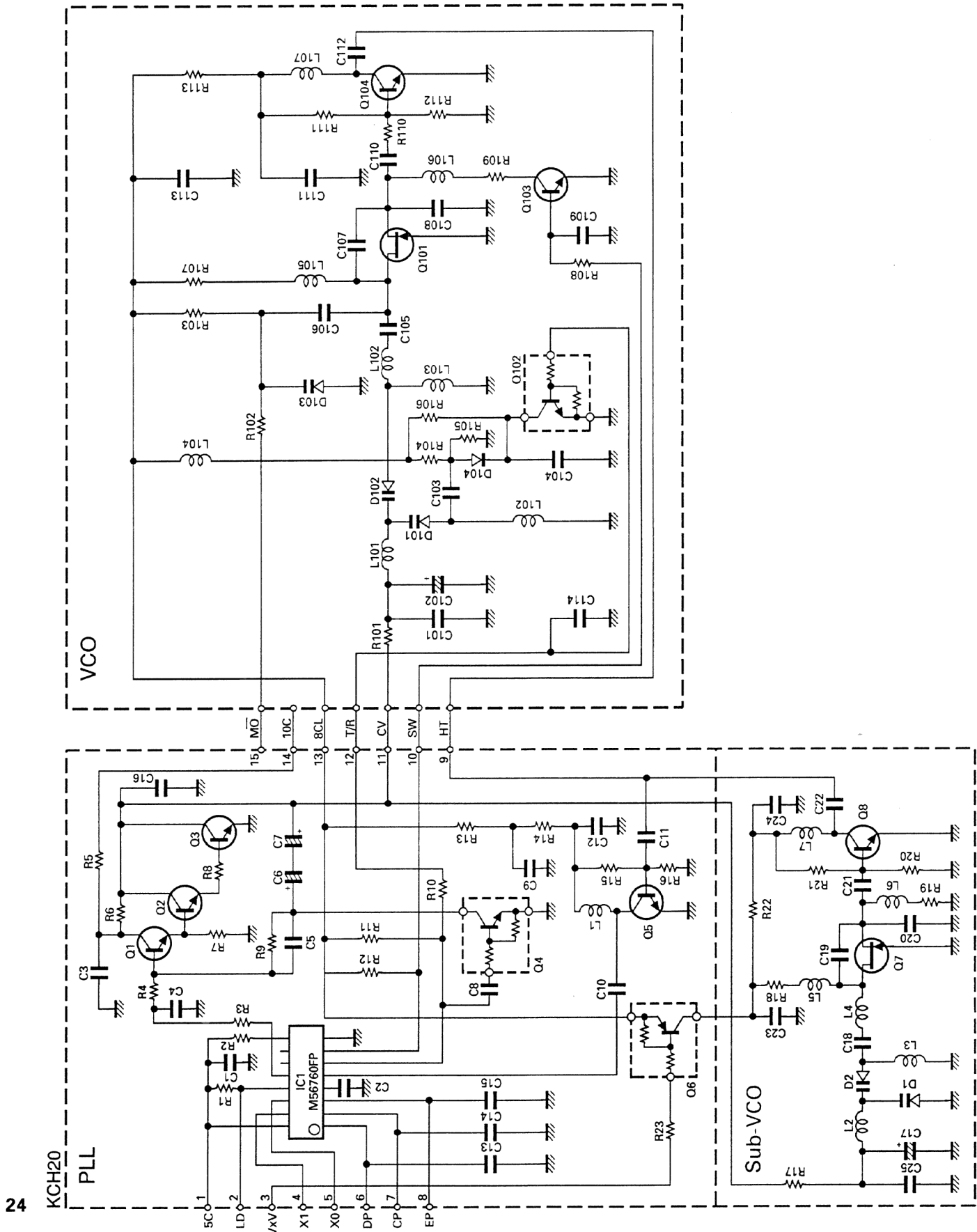

SEMICONDUCTOR DATA

800MHz Front-End : KCB28 (TX-RX Unit B/4 IC202) Except K,P Type

• Schematic diagram

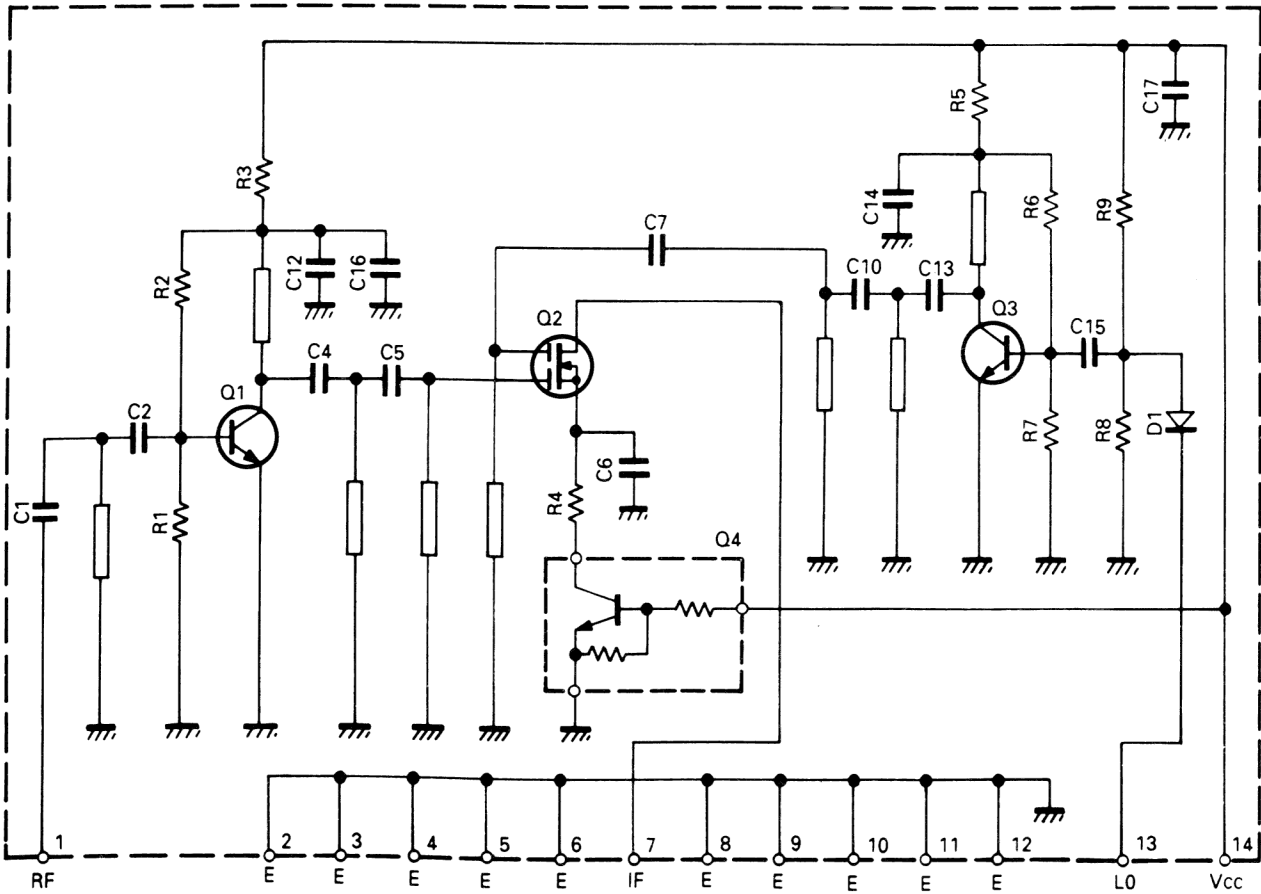

DESCRIPTION OF COMPONENTS

TX-RX UNIT (X57-436X-XX) 0-11 : K,P 0-21 : M 0-22 : M2,M3 0-23 : M4 2-71 : E,E3,E9 2-72 : E2

Ref. No	Use/Function	Operation/Condition compatibility
Q1	High-frequency amplifier	
Q3	High-frequency amplifier	
Q4	First mixer	Except U ²
Q5	First mixer switch	Off for U ²
Q6	First IF amplifier	45.05MHz
Q9	Squelch hysteresis	On when squelch is on
Q10	RD buffer amplifier	
Q11	Power switching 14R	Except U ²
Q12	Power switching 43R	On for U ²
Q13	First mixer	U ²
Q14	First mixer switch	On for U ²
Q15~Q19	<p>During transmission Q15, Q16, Q19 : Off Q17 and Q18 : On</p> <p>During reception Q15, Q16, Q19 : On Q17 and Q18 : Off</p>	<p>The diagram shows a complex circuit involving several transistors and integrated circuits. Q16 and Q17 are at the top, connected to points 8R, 8C, and 8T. Q15 is a central transistor controlled by IC8-4. Q18 and Q19 are at the bottom, with Q19 controlled by IC9-LD. Diodes D8 and D9 are also present. Various resistors and capacitors are used for biasing and timing.</p>
Q20	Squelch switch	See IC4 operation
Q21	Modulation mute	On during reception
Q22, Q23	Inverter	
Q24	CV line buffer	
Q25	VCO output amplifier	
Q26	PLL 8V ripple filter	
Q27	Power switching between medium and low	
Q28	APC control	
Q29	12.8MHz buffer	
Q30	AIP switch	On for AIP on
Q201	High-frequency amplifier	
Q202	Power switching	43R
Q204	High-frequency amplifier	
Q205	AIP switch	On for AIP on
Q206	First mixer	Except V ²
Q207	First mixer switch	Off for V ²
Q208	First IF amplifier	58.525MHz
Q209	Squelch hysteresis	On when squelch is on
Q210	RD buffer amplifier	
Q211	High-frequency amplifier	For V ²
Q212	First mixer	For V ²
Q213	First mixer switch	On for V ²

DESCRIPTION OF COMPONENTS

Ref. No	Use/Function	Operation/Condition compatibility
Q214~Q218	During transmission Q214, Q215, Q216 : Off Q217 and Q218 : On During reception Q214, Q215, Q216 : On Q217 and Q218 : Off	
Q219	Squelch switch	See IC204 operation
Q220	Power switching 14R	On for V ²
Q221~Q223	Inverter	
Q224	Modulation mute	On during reception
Q228	PLL 8V ripple filter	
Q229	VCO output amplifier	
Q230	Fan switch	
Q231	Power switching between medium and low	
Q232	APC control	
Q233	Power switch	
Q234	Power switch control	
Q236	12.8MHz amplifier	
Q401	Data communication squelch switch	On for busy
Q402	9600 bps RD buffer amplifier	
Q403	DTMF signal buffer amplifier	
Q404, Q405	Beep mute	Q404 : UHF, Q405 : VHF
Q406	MIC RD buffer amplifier	
Q407, Q408	AF amplifier	Q407 : VHF, Q408 : UHF
Q409, Q410	AF mute	Q409 : VHF, Q4010 : UHF
Q411, Q412	Speaker output mute	Q411 : External speaker, Q412 : Internal speaker
Q413	Back up switch	On when 7.5V or more
Q414	Reset switch	
Q415	5C switch	
Q416	MIC RD mute	
Q417	Mic mute	
Q418	1200 bps RD buffer amplifier	
Q420	Data communication inhibit transmission switch	On when high level input
Q421	Data communication transmission switch	On during data transmission
Q422	Data communication transmission switch control	On during data transmission
Q423, Q424	Electric volume buffer amplifier	Q423 : UHF, Q424 : VHF
Q425	Packet data buffer amplifier	

DESCRIPTION OF COMPONENTS

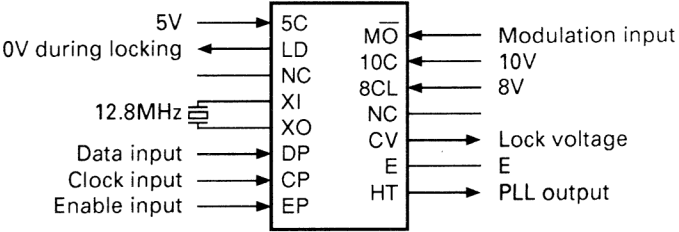
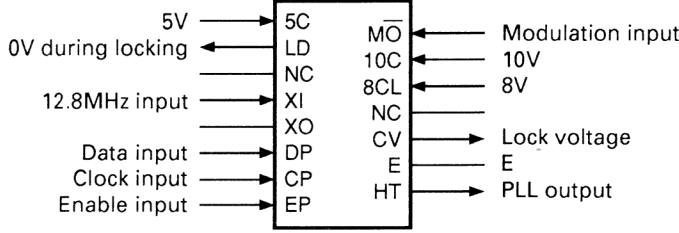
Ref. No	Use/Function	Operation/Condition compatibility
IC1	Second local oscillator, Mixer, IF amplifier, Detection, Low-frequency amplifier, Noise amplifier, Noise detector, Squelch switching	1 : First IF input, 45.05MHz 3,4 : Second local oscillator, 45.505MHz 9 : Scan control busy signal, 0V while busy 10 : Noise-detection voltage output (DC) 11 : S-meter output 12 : Detection output 14 : RD output 15 : AF output
IC3	High-frequency amplifier	U ²
IC4	Analog switch (squelch)	See circuit description
IC5	Shift register	For squelch
IC6	AF amplifier	
IC7	Multiplexer (AF output)	See circuit description
IC8	Shift register	See circuit description
IC9	PLL	
IC10	144MHz-band transmit driver	
IC11	10V AVR	
IC201	Second local oscillator, Mixer, IF amplifier, Detection, Low-frequency amplifier, Noise amplifier, noise detector, Squelch switching	1 : First IF input, 58.525MHz 3,4 : Second local oscillator, 58.07MHz 9 : Scan control busy signal, 0V while busy 10 : Noise-detection voltage output (DC) 11 : S-meter output 12 : Detection output 14 : RD output 15 : AF output
IC204	Analog switch (squelch)	See circuit description
IC205	Shift register	For squelch
IC206	Shift register	See circuit description
IC207	PLL	
IC208	10V AVR	
IC209	430MHz-band transmit driver	
IC210	APC	
IC211	8V AVR	
IC401	DTMF decoder	
IC402	DTMF encoder	
IC403	Microprocessor	See circuit description
IC404	Analog switch	See circuit description
IC405, IC406	Multiplexer	See circuit description
IC407	Electric volume	Rch : VHF band, Lch : UHF band
IC408	6V AVR	
IC409, IC410	Serial data inverter	
IC411	Analog switch	See circuit description
IC412, IC413	Low-frequency amplifier	Microphone amplifier

DESCRIPTION OF COMPONENTS

Ref. No	Use/Function	Operation/Condition compatibility
D1~D5	Vari-cap tuning	
D6	Heterodyne switch	
D7	Reference voltage	
D8	Reverse-flow prevention	
D9	Voltage correction	
D10	Heterodyne switch	Transmit/receive switch
D11	Reverse-flow prevention	
D12	APC temperature compensation	
D13, D14	Antenna selection switch	
D15, D16	Power detection	
D17	Vari-cap tuning	
D18, D19	Reverse-flow prevention	
D202	Reverse-flow prevention	
D203	IF level limiter	
D204, D205	Heterodyne switch	
D206, D207	Reverse-flow prevention	
D210	Heterodyne switch	Transmit/receive switch
D211	APC temperature compensation	
D212	Reverse-flow prevention	
D213, D214	Antenna selection switch	
D215, D216	Power detection	
D217	Reverse power connection prevention	
D401~D404	Reverse-flow prevention	
D405	Backup detection	
D406	Reset detection	
D407, D408	Reverse-flow prevention	
D409	Surge protection	
D411	Regulation	

PARTS LIST

× New Parts

Parts without Parts No. are not supplied.

Les articles non mentionnés dans le Parts No. ne sont pas fournis.

Teile ohne Parts No. werden nicht geliefert.

TM-733A/E

Ref. No. 参照番号	Address 位置	New Parts 新	Parts No. 部品番号	Description 部品名 / 規格	Desti- nation 仕 向	Re- marks 備考
TM-733A/E						
1	3C	*	A01-2082-03	METALLIC CABINET(BOTTOM)		
2	1C	*	A01-2083-03	METALLIC CABINET(TOP)		
3	2D	*	A62-0280-12	PANEL (BODY)		
4	3A	*	A62-0281-33	PANEL ASSY(SEPARATE)		
5	3B	*	A82-0016-02	BACK PANEL(SAPARATE)		
6	3B	*	B38-0708-25	LCD ASSY	M4	
7	3B	*	B38-0709-25	LCD ASSY	KPMM2	
7	3B	*	B38-0709-25	LCD ASSY	M3E2	
7	3B	*	B38-0709-25	LCD ASSY	E3E9	
8	2D		B42-3322-14	LABEL (ANT)	KP	
9	3C		B42-3343-04	LABEL (S/NO)		
10	3C		B42-3394-14	LABEL (FCC)	K	
11	-		B42-5526-04	LABEL (HYATT)	K	
12	-		B46-0310-03	USER & WARRNTY CARD	:ACSY	EE3E9
13	-		B46-0410-30	USER & WARRNTY CARD	:ACSY	K
14	-		B46-0422-00	USER & WARRNTY CARD	:ACSY	P
15	-	*	B62-0391-00	INSTRUCTION MANUAL	:ACSY	
16	-	*	B62-0392-00	INSTRUCTION MANUAL	:ACSY	EE2
17	-	*	B62-0393-00	INSTRUCTION MANUAL	:ACSY	MM2M3
17	-	*	B62-0393-00	INSTRUCTION MANUAL	:ACSY	PE3
18	-	*	B62-0394-00	INSTRUCTION MANUAL	:ACSY	MM2M3
18	-	*	B62-0394-00	INSTRUCTION MANUAL	:ACSY	PE3E9
19	-	*	B62-0466-00	INSTRUCTION MANUAL	:ACSY	M4
20	3C	*	B72-0592-04	MODEL NAME PLATE		MM2M3
20	3C	*	B72-0592-04	MODEL NAME PLATE		M4
21	3C	*	B72-0593-04	MODEL NAME PLATE		EE2E3
21	3C	*	B72-0593-04	MODEL NAME PLATE		E9
22	3C		B72-0651-14	MODEL NAME PLATE		E9
23	3C	*	B72-0740-04	MODEL NAME PLATE		KP
-			E23-0435-05	TERMINAL(TEST)		
25	2D		E30-2108-05	ANT CABLE ASSY(N)		EE2E3
25	2D		E30-2108-05	ANT CABLE ASSY(N)		E9
26	-		E30-2111-05	DC POWER CORD ASSY	:ACSY	
27	2D		E30-2145-15	ANT CABLE ASSY(M)		KPMM2
27	2D		E30-2145-15	ANT CABLE ASSY(M)		M3M4
28	1D		E30-3007-05	DC CORD ASSY(BODY)		
29	2D		E30-3009-15	ANT CABLE ASSY(M WITH COVER)		KP
-			E30-3206-08	CUAL CORD ASSY (MIC)		MM2M4
-			E30-3206-08	CUAL CORD ASSY (MIC)		EE2E3
-			E30-3206-08	CUAL CORD ASSY (MIC)		E9
-			E30-3208-08	CUAL CORD ASSY (MIC)		KPM3
32	1C		E31-3197-15	CONNECTING WIRE(SP)		
33	2C	*	E37-0401-05	FLAT CABLE (21P)		
34	2C	*	E37-0402-05	FLAT CABLE (19P)		
35	2C		E40-5021-05	PIN ASSY (7P:CN202)		
36	1C		E40-5537-05	PIN CONNECTOR ASSY(7P:CN3)		
37	1D		F07-1347-03	COVER (FAN)		
38	3B	*	F07-1376-04	COVER (DIN:6P)		
39	1C		F10-2039-04	SHIELDING COVER(VHF)		
40	3D	*	F10-2128-04	SHIELDING COVER(UHF)		
41	-		F51-0017-05	FUSE (15A)	:ACSY	
42	1D		F51-0017-05	FUSE (15A)		

L:Scandinavia

K:USA

P:Canada

Y:PX(Far East, Hawaii)

T:England

E:Europe

Y:AAFES(Europe)

X:Australia

M:Other Areas

TM-733A : K, P, M, M2, M3, M4

TM-733E : E, E2, E3, E9

⚠ indicates safety critical components.

PARTS LIST

× New Parts

Parts without **Parts No.** are not supplied.

Les articles non mentionnés dans le **Parts No.** ne sont pas fournis.

Teile ohne **Parts No.** werden nicht geliefert.

TM-733A/E

Ref. No. 参照番号	Address 位置	New Parts 新	Parts No. 部品番号	Description 部品名 / 規格	Desti- nation 仕向	Re- marks 備考
- 43	2B		F51-0018-05 F29-0450-05	FUSE (20A:DC POWER CORD) INSULATOR		
44	2A	*	G01-0878-04	COIL SPRING(RELEASE)		
45	1C		G02-0721-14	FLAT SPRING(APC)		
46	1C	*	G02-0743-04	FLAT SPRING(THERMAL SW)		
47	3C	*	G02-0748-04	FLAT SPRING(TRANSISTOR)		
49	2B, 3B		G10-0655-04	AUXILIARY PART(BODY PANEL)		
50	3A	*	G11-0709-03	SHEET		
51	3B	*	G11-0710-14	SHEET (LARGE SIZE)		
52	2B	*	G11-0713-04	SHEET (SMALL SIZE)		
53	3C		G13-0820-14	CUSHION(to C355)		
54	3A, 3B	*	G13-1407-04	CUSHION(PANEL)		
55	-	*	H10-2776-02	POLYSTYRENE FOAMED FIXTURE		
56	-		H13-0814-04	CARTON BOARD(BRACKET)		
57	-		H13-0825-04	CARTON BOARD		
58	-		H13-0843-04	CARTON BOARD	EE2	
59	-		H25-0117-04	BAG (80X250)		
60	-		H25-0720-04	BAG (200X350)		
61	-		H25-0750-04	BAG (170X270)		
62	-	*	H52-0476-04	ITEM CARTON BOX	KP	
63	-	*	H52-0477-04	ITEM CARTON BOX	MM2M3	
63	-	*	H52-0477-04	ITEM CARTON BOX	M4	
64	-	*	H52-0478-04	ITEM CARTON BOX	EE2E3	
64	-	*	H52-0478-04	ITEM CARTON BOX	E9	
65	-		J20-0319-24	HOOK : ACSY	KP	
66	1B	*	J21-4446-04	HARDWARE FIXTURE(SP)		
67	-		J29-0436-03	BRACKET : ACSY		
68	2D		J42-0453-05	BUSHING (ANT)	MM2M3	
68	2D		J42-0453-05	BUSHING (ANT)	M4EE2	
68	2D		J42-0453-05	BUSHING (ANT)	E3E9	
-		*	K27-3140-12	KNOB (8 KEYS)		
70	3A	*	K27-3141-04	KNOB (VFO)		
71	3A	*	K27-3142-04	KNOB (MR)		
72	3A	*	K27-3143-04	KNOB (PWR)		
73	3A	*	K27-3144-04	KNOB (PM)		
74	2A	*	K27-3145-04	KNOB (RELEASE)		
75	3A	*	K27-3146-04	KNOB (MAIN PUSH)		
76	3A	*	K29-4887-04	KNOB (MAIN)		
77	3A	*	K29-4888-04	KNOB (VOL)		
78	3A	*	K29-4889-04	KNOB (SQL)		
79	3A		N14-0552-05	NUT (VOL)		
A	1C, 3C		N33-2606-45	OVAL HEAD MACHIN SCREW(CASE)		
B	1D		N35-2608-45	BINDING HEAD MACHINE SCREW		
C	1C, 3D		N67-3010-46	SCREW (M3X10)		
D	2B, 3B		N80-2010-45	SCREW (PANEL)		
E	1C, 2D		N80-2610-45	SCREW (FAN)		
F	1C, 3C		N87-2606-46	BRAZIER HEAD TAPTITE SCREW		
80	-		N99-0331-05	SCREW SET : ACSY	MM2M3	
80	-		N99-0331-05	SCREW SET : ACSY	M4EE2	
80	-		N99-0331-05	SCREW SET : ACSY	E3E9	
81	-	*	N99-0382-05	SCREW SET : ACSY	KP	
SP	1B		T07-0246-05	LOUDSPEAKER(16 ohm 1w)		

L:Scandinavia

K:USA

P:Canada

Y:PX(Far East, Hawaii)

T:England

E:Europe

Y:AAFES(Europe)

X:Australia

M:Other Areas

TM-733A : K, P, M, M2, M3, M4
TM-733E : E, E2, E3, E9

 indicates safety critical components.

PARTS LIST

× New Parts

Parts without **Parts No.** are not supplied.

Les articles non mentionnés dans le **Parts No.** ne sont pas fournis.

Teile ohne **Parts No.** werden nicht geliefert.

TM-733A/E

TX-RX UNIT (X57-436X-XX)

Ref. No. 参照番号	Address 位置	New Parts 新	Parts No. 部品番号	Description 部品名 / 規格	Desti- nation 仕向	Re- marks 備考
FAN	2D		T42-0311-15	DC MOTOR (FAN)		
MIC	-		T91-0516-05	MICROPHONE : ACSY	MM2M4	
MIC	-		T91-0516-05	MICROPHONE : ACSY	EE2E3	
MIC	-		T91-0516-05	MICROPHONE : ACSY	E9	
MIC	-		T91-0517-05	MICROPHONE : ACSY	KPM3	
IC501	2C		M57788MR	IC(POWER MODULE/430-450MHZ)		
IC502	1C		S-AV17	IC(POWER MODULE FOR 144MHZ)		
82	-		W01-0414-04	SPANNER : ACSY		
700	1C, 2C	*	X57-4360-11	TX-RX UNIT (A/4...D/4)	KP	
700	1C, 2C	*	X57-4360-21	TX-RX UNIT (A/4...D/4)	M	
700	1C, 2C	*	X57-4360-22	TX-RX UNIT (A/4...D/4)	M2M3	
700	1C, 2C	*	X57-4360-23	TX-RX UNIT (A/4...D/4)	M4	
700	1C, 2C	*	X57-4362-71	TX-RX UNIT (A/4...D/4)	EE3E9	
700	1C, 2C	*	X57-4362-72	TX-RX UNIT (A/4...D/4)	E2	
TX-RX UNIT (X57-436X-XX) 0-11 : K, P 0-21 : M 0-22 : M2, M3 0-23 : M4 2-71 : E, E3, E9 2-72 : E2						
C1			CC73FCH1H010C	CHIP C 1PF C		
C2			CC73FCH1H060D	CHIP C 6PF D		
C3 -8			CK73FB1H102K	CHIP C 1000PF K		
C9			CC73FCH1H060D	CHIP C 6PF D		
C10			CK73FB1H102K	CHIP C 1000PF K		
C11			CC73FCH1H060D	CHIP C 6PF D		
C12 -14			CK73FB1H102K	CHIP C 1000PF K		
C15			CC73FCH1H221J	CHIP C 220PF J		
C16			CC73FCH1H0R5C	CHIP C 0.5PF C		
C17 -19			CK73FB1H102K	CHIP C 1000PF K		
C20 ,21			CC73FCH1H150J	CHIP C 15PF J		
C22			CC73FCH1H060D	CHIP C 6PF D		
C24			CC73FCH1H040C	CHIP C 4PF C		
C25			CK73FB1H102K	CHIP C 1000PF K		
C26 ,27			CK73FB1E103K	CHIP C 0.01UF K		
C28			CC73FCH1H080D	CHIP C 8PF D		
C29			CK73FB1E103K	CHIP C 0.01UF K		
C30 -32			CK73FB1H102K	CHIP C 1000PF K		
C33			CK73FB1E103K	CHIP C 0.01UF K		
C34			CE04NW1C470M	ELECTRO 47UF 16WV		
C35			CC73FCH1H270J	CHIP C 27PF J		
C36			CK73FB1H102K	CHIP C 1000PF K		
C37			CC73FCH1H180J	CHIP C 18PF J		
C38			CE04NW1E100M	ELECTRO 10UF 25WV		
C39			CK73FB1H102K	CHIP C 1000PF K		
C40			C92-0003-05	CHIP TAN 0.47UF 25WV		
C41			CK73FF1C105Z	CHIP C 1.0UF Z		
C42			CK73FF1C474Z	CHIP C 0.47UF Z		
C43 ,44			CK73FF1C105Z	CHIP C 1.0UF Z		
C45 -48			CK73FB1H102K	CHIP C 1000PF K		
C49			CK73FB1E103K	CHIP C 0.01UF K		
C50			CK73FF1C105Z	CHIP C 1.0UF Z		
C51 -53			CK73FB1H102K	CHIP C 1000PF K		
C54			CC73FCH1H120J	CHIP C 12PF J		
C55			CC73FCH1H150J	CHIP C 15PF J		
C56			CC73FCH1H060D	CHIP C 6PF D		
C57			CC73FCH1H150J	CHIP C 15PF J		
C58 ,59			CC73FCH1H060D	CHIP C 6PF D		

L:Scandinavia

K:USA

P:Canada

Y:PX(Far East, Hawaii)

T:England

E:Europe

Y:AAFES(Europe)

X:Australia

M:Other Areas

TM-733A : K, P, M, M2, M3, M4

TM-733E : E, E2, E3, E9

⚠ indicates safety critical components.

PARTS LIST

× New Parts

Parts without Parts No. are not supplied.

Les articles non mentionnés dans le Parts No. ne sont pas fournis.

Teile ohne Parts No. werden nicht geliefert.

TX-RX UNIT (X57-436X-XX)

Ref. No. 参照番号	Address 位置	New Parts 新	Parts No. 部品番号	Description 部品名 / 規格	Desti- nation 仕 向	Re- marks 備考
C60			CC73FCH1H040C	CHIP C 4PF C		
C61			CC73FCH1H060D	CHIP C 6PF D		
C62			CC73FCH1H050C	CHIP C 5PF C		
C63 -65			CC73FCH1H060D	CHIP C 6PF D		
C66			CC73FCH1H080D	CHIP C 8PF D		
C67			CC73FCH1H180J	CHIP C 18PF J		
C68			CC73FCH1H120J	CHIP C 12PF J		
C69			CC73FCH1H101J	CHIP C 100PF J		
C70			CK73FB1H102K	CHIP C 1000PF K		
C71			CK73FB1E103K	CHIP C 0.01UF K		
C72 ,73			CE04EW1C470M	ELECTRO 47UF 16WV		
C74			C92-0504-05	CHIP TAN 0.68UF 20WV		
C75			CE04EW1C470M	ELECTRO 47UF 16WV		
C76			CK73FB1E103K	CHIP C 0.01UF K		
C77			CK73FB1E123K	CHIP C 0.012UF K		
C78			CE04EW1C101M	ELECTRO 100UF 16WV		
C79			CC73FSL1H101J	CHIP C 100PF J		
C80			CE04EW1H470M	ELECTRO 47UF 50WV		
C81			CE04EW1C470M	ELECTRO 47UF 16WV		
C82			CE04EW1C471M	ELECTRO 470UF 16WV		
C83 ,84			CK73FB1E104K	CHIP C 0.10UF K		
C85			CE04EW1C471M	ELECTRO 470UF 16WV		
C86			CE04EW1C470M	ELECTRO 47UF 16WV		
C87			CE04EW1H470M	ELECTRO 47UF 50WV		
C88			CK73FB1E123K	CHIP C 0.012UF K		
C89 ,90			CK73FB1H102K	CHIP C 1000PF K		
C91 -93			CC73FSL1H101J	CHIP C 100PF J		
C94			CK73FB1H102K	CHIP C 1000PF K		
C96			CK73FB1H102K	CHIP C 1000PF K		
C97 ,98			CC73FSL1H101J	CHIP C 100PF J		
C99			CK73FB1E103K	CHIP C 0.01UF K		
C100			CK73FB1H102K	CHIP C 1000PF K		
C101			CE04CW1C100M	ELECTRO 10UF 16WV		
C102			CC73FUJ1H150J	CHIP C 15PF J		
C103			CC73FUJ1H180J	CHIP C 18PF J		
C104			CE04EW1C470M	ELECTRO 47UF 16WV		
C105			CK73FB1H102K	CHIP C 1000PF K		
C106		*	C92-0606-05	CHIP TAN 4.7UF 10WV		
C107, 108			CK73FB1H102K	CHIP C 1000PF K		
C109			CC73FSL1H101J	CHIP C 100PF J		
C110			CE04EW1A221M	ELECTRO 220UF 10WV		
C111			CK73FB1H102K	CHIP C 1000PF K		
C112			CK73FB1E103K	CHIP C 0.01UF K		
C113			CE04EW1E100M	ELECTRO 10UF 25WV		
C114			CE04EW1A330M	ELECTRO 33UF 10WV		
C115			CK73FB1E103K	CHIP C 0.01UF K		
C116			CC73FCH1H560J	CHIP C 56PF J		
C117			CK73FB1H102K	CHIP C 1000PF K		
C118			CC73FCH1H100D	CHIP C 10PF D		
C119			CK73FB1E103K	CHIP C 0.01UF K		
C120			CE04EW1C101M	ELECTRO 100UF 16WV		
C121			CC73FCH1H020C	CHIP C 2.0PF C		
C122			CK73FB1H102K	CHIP C 1000PF K		
C123			CK73FB1E223K	CHIP C 0.022UF K		
C124			CK73FB1H102K	CHIP C 1000PF K		

L:Scandinavia

K:USA

P:Canada

Y:PX(Far East, Hawaii)

T:England

E:Europe

Y:AAFES(Europe)

X:Australia

M:Other Areas

TM-733A : K, P, M, M2, M3, M4

TM-733E : E, E2, E3, E9

⚠ indicates safety critical components.

PARTS LIST

× New Parts

Parts without Parts No. are not supplied.

Les articles non mentionnes dans le Parts No. ne sont pas fournis.

Teile ohne Parts No. werden nicht geliefert.

TX-RX UNIT (X57-436X-XX)

Ref. No. 参照番号	Address 位置	New Parts 新	Parts No. 部品番号	Description 部品名 / 規格	Desti- nation 仕向	Re- marks 備考
C125			CK73FB1H472K	CHIP C 4700PF K		
C126, 127			CK73FB1H102K	CHIP C 1000PF K		
C128			CK73FF1C105Z	CHIP C 1.0UF Z		
C129			CE04EW1E100M	ELECTRO 10UF 25WV		
C130			CK73FB1H102K	CHIP C 1000PF K		
C131			CK73FF1C105Z	CHIP C 1.0UF Z		
C132			CK73FB1H102K	CHIP C 1000PF K		
C133			CK73FB1E103K	CHIP C 0.01UF K		
C134			CK73FB1H102K	CHIP C 1000PF K		
C135			CE04CW1C100M	ELECTRO 10UF 16WV		
C137			CC45SL2H100D	CERAMIC 10PF D		
C138			CK45B2H102K	CERAMIC 1000PF K		
C139			CC45SL2H330J	CERAMIC 33PF J		
C140			CC73FCH1H0R5C	CHIP C 0.5PF C		
C141			CC73FCH1H030C	CHIP C 3PF C		
C142			CK73FB1H102K	CHIP C 1000PF K		
C143			CC45SL2H560J	CERAMIC 56PF J		
C144			CC45SL2H470J	CERAMIC 47PF J		
C145, 146			CK73FB1H102K	CHIP C 1000PF K		
C147			CC73FCH1H030C	CHIP C 3PF C		
C148			CC73FCH1H0R5C	CHIP C 0.5PF C		
C149			CM73F2H300J	CHIP C 30PF J	KP	
C149			CM73F2H330J	CHIP C 33PF J	MM2M3	
C149			CM73F2H330J	CHIP C 33PF J	M4EE2	
C149			CM73F2H330J	CHIP C 33PF J	E3E9	
C150			CM73F2H080D	CHIP C 8.0PF D		
C151			CC73FCH1H220J	CHIP C 22PF J		
C153			CC73FCH1H050C	CHIP C 5PF C		
C155, 156			CK73FF1C105Z	CHIP C 1.0UF Z		
C157, 158			CK73FB1E103K	CHIP C 0.01UF K		
C159			CC73FCH1H050C	CHIP C 5PF C		
C161			CK73FB1E103K	CHIP C 0.01UF K		
C162-165			CK73FB1H102K	CHIP C 1000PF K		
C201			CC73FCH1H010C	CHIP C 1PF C		
C202-205			CK73FB1H102K	CHIP C 1000PF K		
C206			CC73FCH1H060D	CHIP C 6PF D		
C207			CK73FB1H102K	CHIP C 1000PF K		
C209			CC73FSL1H101J	CHIP C 100PF J		
C210-212			CK73FB1H102K	CHIP C 1000PF K		
C213			CC73FCH1H1R5C	CHIP C 1.5PF C		
C215			CC73FCH1H010C	CHIP C 1PF C		
C216-220			CK73FB1H102K	CHIP C 1000PF K		
C221			CC73FCH1H050C	CHIP C 5PF C		
C222			CC73FCH1H040C	CHIP C 4PF C		
C223-225			CK73FB1H102K	CHIP C 1000PF K		
C226			CC73FCH1H030C	CHIP C 3PF C	MM2M3	
C226			CC73FCH1H030C	CHIP C 3PF C	M4EE2	
C226			CC73FCH1H030C	CHIP C 3PF C	E3E9	
C226			CC73FCH1H050C	CHIP C 5PF C	KP	
C227			CK73FB1H102K	CHIP C 1000PF K		
C228			CC73FCH1H120J	CHIP C 12PF J		
C229-231			CK73FB1H102K	CHIP C 1000PF K		
C232, 233			CC73FCH1H180J	CHIP C 18PF J		
C234, 235			CK73FB1H102K	CHIP C 1000PF K		
C236			CE04NW1C470M	ELECTRO 47UF 16WV		

L:Scandinavia

K:USA

P:Canada

Y:PX(Far East, Hawaii)

T:England

E:Europe

Y:AAFES(Europe)

X:Australia

M:Other Areas

TM-733A : K, P, M, M2, M3, M4

TM-733E : E, E2, E3, E9

△ indicates safety critical components.

PARTS LIST

× New Parts

Parts without **Parts No.** are not supplied.

Les articles non mentionnes dans le **Parts No.** ne sont pas fournis.

Teile ohne **Parts No.** werden nicht geliefert.

TX-RX UNIT (X57-436X-XX)

Ref. No. 参照番号	Address 位置	New Parts 新	Parts No. 部品番号	Description 部品名 / 規格	Desti- nation 仕 向	Re- marks 備考
C237			CK73FB1H102K	CHIP C 1000PF K		
C239			C92-0003-05	CHIP TAN 0.47UF 25WV		
C240, 241			CK73FF1C105Z	CHIP C 1.0UF Z		
C242			CK73FF1C474Z	CHIP C 0.47UF Z		
C243			CK73FB1H102K	CHIP C 1000PF K		
C244			CK73FF1C105Z	CHIP C 1.0UF Z		
C245-248			CK73FB1H102K	CHIP C 1000PF K		
C251			CC73FCH1H150J	CHIP C 15PF J		
C252, 253			CK73FB1H102K	CHIP C 1000PF K		
C254			CC73FCH1H270J	CHIP C 27PF J		
C255			CC73FCH1H180J	CHIP C 18PF J		
C256			CC73FCH1H220J	CHIP C 22PF J		
C257			CC73FCH1H060D	CHIP C 6PF D		
C258			CC73FCH1H180J	CHIP C 18PF J		
C259			CC73FCH1H100D	CHIP C 10PF D		
C260			CC73FCH1H090D	CHIP C 9PF D		
C261, 262			CK73FB1H102K	CHIP C 1000PF K		
C263			CE04NW1C470M	ELECTRO 47UF 16WV		
C264			C92-0504-05	CHIP TAN 0.68UF 20WV		
C265, 266			CE04NW1C470M	ELECTRO 47UF 16WV		
C267, 268			CK73FB1H102K	CHIP C 1000PF K		
C269, 270			CC73FSL1H101J	CHIP C 100PF J		
C271, 272			CK73FB1H102K	CHIP C 1000PF K		
C273			CC73FSL1H101J	CHIP C 100PF J		
C274			CK73FB1H102K	CHIP C 1000PF K		
C275, 276			CC73FSL1H101J	CHIP C 100PF J		
C277-282			CK73FB1H102K	CHIP C 1000PF K		
C283			CE04NW1C470M	ELECTRO 47UF 16WV		
C284			CK73FB1H102K	CHIP C 1000PF K		
C285			CK73FB1H822K	CHIP C 8200PF K		
C286			CK73FB1H102K	CHIP C 1000PF K		
C287		*	C92-0606-05	CHIP TAN 4.7UF 10WV		
C289			CE04NW1C100M	ELECTRO 10UF 16WV		
C290-292			CC73FSL1H101J	CHIP C 100PF J		
C300			CC73FSL1H101J	CHIP C 100PF J		
C301			CK73FB1H102K	CHIP C 1000PF K		
C302			CE04NW1A221M	ELECTRO 220UF 10WV		
C303			CK73FB1H102K	CHIP C 1000PF K		
C304			CE04NW1A330M	ELECTRO 33UF 10WV		
C305			CE04NW1A221M	ELECTRO 220UF 10WV		
C306-308			CK73FB1H102K	CHIP C 1000PF K		
C309			CE04NW1C101M	ELECTRO 100UF 16WV		
C310			CC73FCH1H030C	CHIP C 3PF C		
C311			CK73FB1H102K	CHIP C 1000PF K		
C312			CC73FCH1H060D	CHIP C 6PF D		
C313			CK73FB1H102K	CHIP C 1000PF K		
C314			CE04NW1C101M	ELECTRO 100UF 16WV		
C315-323			CK73FB1H102K	CHIP C 1000PF K		
C325			CK73FB1H102K	CHIP C 1000PF K		
C326			CK73FB1E104K	CHIP C 0.10UF K		
C327			CK73FB1H102K	CHIP C 1000PF K		
C328			CK73FB1E333K	CHIP C 0.033UF K		
C329			CK73FB1E103K	CHIP C 0.01UF K		
C330			CM73F2H040D	CHIP C 4.0PF D		KP
C330			CM73F2H060D	CHIP C 6.0PF D		MM2M3

L:Scandinavia

K:USA

P:Canada

Y:PX(Far East, Hawaii)

T:England

E:Europe

Y:AAFES(Europe)

X:Australia

M:Other Areas

TM-733A : K, P, M, M2, M3, M4
TM-733E : E, E2, E3, E9

 indicates safety critical components.

PARTS LIST

× New Parts

Parts without Parts No. are not supplied.

Les articles non mentionnes dans le Parts No. ne sont pas fournis.

Teile ohne Parts No. werden nicht geliefert.

TX-RX UNIT (X57-436X-XX)

Ref. No. 参照番号	Address 位置	New Parts 新	Parts No. 部品番号	Description 部品名 / 規格	Desti- nation 仕向	Re- marks 備考
C330			CM73F2H060D	CHIP C 6.0PF D	M4EE2	
C330			CM73F2H060D	CHIP C 6.0PF D	E3E9	
C331, 332			CK73FB1H102K	CHIP C 1000PF K		
C333			CC45SL2H060D	CERAMIC 6.0PF D		
C334			CC45SL2H090D	CERAMIC 9.0PF D		
C335			CC73FCH1H0R5C	CHIP C 0.5PF C		
C336			CC73FCH1H020C	CHIP C 2.0PF C		
C337			CK73FB1H102K	CHIP C 1000PF K		
C338			CC45SL2H070D	CERAMIC 7.0PF D		
C339			CC73FCH1H0R5C	CHIP C 0.5PF C		
C340			CK73FB1H102K	CHIP C 1000PF K		
C341			CC73FCH1H020C	CHIP C 2.0PF C		
C342			CC45SL2H070D	CERAMIC 7.0PF D		
C343			CC45SL2H050C	CERAMIC 5.0PF C		
C344			CC45SL2H390J	CERAMIC 39PF J		
C345			CC45SL2H070D	CERAMIC 7.0PF D		
C346			CC73FCH1HR75C	CHIP C 0.75PF C	MM2M3	
C346			CC73FCH1HR75C	CHIP C 0.75PF C	M4EE2	
C346			CC73FCH1HR75C	CHIP C 0.75PF C	E3E9	
C347			CC73FCH1H010C	CHIP C 1PF C	MM2M3	
C347			CC73FCH1H010C	CHIP C 1PF C	M4EE2	
C347			CC73FCH1H010C	CHIP C 1PF C	E3E9	
C349			CK73FB1H102K	CHIP C 1000PF K		
C350			CK73FB1E103K	CHIP C 0.01UF K		
C351			CE04NW1A101M	ELECTRO 100UF 10WV		
C352			CK73FB1E103K	CHIP C 0.01UF K		
C353, 354			CK73FB1H102K	CHIP C 1000PF K		
C355			C90-2092-05	ELECTRO 10UF 16WV		
C356			CK73FB1H471K	CHIP C 470PF K		
C358			CK73FB1H102K	CHIP C 1000PF K		
C361, 362			CK73FF1C105Z	CHIP C 1.0UF Z		
C363-365			CK73FB1H102K	CHIP C 1000PF K		
C367			CC73FCH1H220J	CHIP C 22PF J		
C368, 369			CK73FB1H102K	CHIP C 1000PF K		
C372, 373			CK73FB1H102K	CHIP C 1000PF K		
C401, 402			CK73FB1E103K	CHIP C 0.01UF K		
C404			CK73FB1H103K	CHIP C 0.010UF K		
C405			CK73FB1H102K	CHIP C 1000PF K		
C406			CK73FB1H332K	CHIP C 3300PF K		
C407			CC73FSL1H151J	CHIP C 150PF J		
C408			CC73FSL1H121J	CHIP C 120PF J		
C409-411			CC73FSL1H101J	CHIP C 100PF J		
C412			CK73FF1C105Z	CHIP C 1.0UF Z		
C413		*	C92-0606-05	CHIP TAN 4.7UF 10WV		
C416-418			CK73FB1E103K	CHIP C 0.01UF K		
C419			CK73FB1H332K	CHIP C 3300PF K		
C420			CC73FSL1H101J	CHIP C 100PF J		
C421			CK73FB1E103K	CHIP C 0.01UF K		
C422, 423			CC73FSL1H101J	CHIP C 100PF J		
C424			CK73FB1H102K	CHIP C 1000PF K		
C425, 426			CC73FCH1H330J	CHIP C 33PF J		
C427, 428			CK73FB1H102K	CHIP C 1000PF K		
C429			CK73FB1H102K	CHIP C 1000PF K	EE2E3	
C429			CK73FB1H102K	CHIP C 1000PF K	E9	
C434			CK73FF1C105Z	CHIP C 1.0UF Z		

L:Scandinavia

K:USA

P:Canada

Y:PX(Far East, Hawaii)

T:England

E:Europe

Y:AAFES(Europe)

X:Australia

M:Other Areas

TM-733A : K, P, M, M2, M3, M4

TM-733E : E, E2, E3, E9

⚠ indicates safety critical components.

PARTS LIST

× New Parts

Parts without Parts No. are not supplied.

Les articles non mentionnes dans le Parts No. ne sont pas fournis.

Teile ohne Parts No. werden nicht geliefert.

TX-RX UNIT (X57-436X-XX)

Ref. No. 参照番号	Address 位置	New Parts 新	Parts No. 部品番号	Description 部品名 / 規格	Desti- nation 仕向	Re- marks 備考
C435, 436			CK73FB1E104K	CHIP C 0.10UF K		
C437, 438			C92-0507-05	CHIP TAN 4.7UF 6.3WV		
C439			CE04CW1A101M	ELECTRO 100UF 10WV		
C440, 441			CC73FSL1H101J	CHIP C 100PF J		
C442, 443			CK73FB1H102K	CHIP C 1000PF K		
C444			CE04CW1A221M	ELECTRO 220UF 10WV		
C445			CK73FF1C105Z	CHIP C 1.0UF Z		
C446			CK73FB1E103K	CHIP C 0.01UF K		
C447			CK73FB1E223K	CHIP C 0.022UF K		
C448			CK73FB1H102K	CHIP C 1000PF K		
C449			CC73FSL1H101J	CHIP C 100PF J		
C450			CK73FF1C105Z	CHIP C 1.0UF Z		
C451-453			CC73FSL1H101J	CHIP C 100PF J		
C454			CK73FB1H102K	CHIP C 1000PF K		
C455			CK73FB1E104K	CHIP C 0.10UF K		
C456			CK73FB1E103K	CHIP C 0.01UF K		
C457		*	C92-0606-05	CHIP TAN 4.7UF 10WV		
C458			C92-0523-05	ELECTRO 10UF 16WV		
C459			CK73FB1E104K	CHIP C 0.10UF K		
C460, 461			CC73FSL1H101J	CHIP C 100PF J		
C462			CK73FB1E393K	CHIP C 0.039UF K		
C463			C92-0507-05	CHIP TAN 4.7UF 6.3WV		
C464			CK73FB1E333K	CHIP C 0.033UF K		
C465			CC73FCH1H270J	CHIP C 27PF J		
C466			CK73FB1E333K	CHIP C 0.033UF K		
C467			CK73FB1H821K	CHIP C 820PF K		
C468			CK73FB1H332K	CHIP C 3300PF K		
C469			CC73FSL1H820J	CHIP C 82PF J		
C470			CC73FSL1H101J	CHIP C 100PF J		
C471			CK73FB1E104K	CHIP C 0.10UF K		
C472			CK73FB1E223K	CHIP C 0.022UF K		
C473-477			CK73FF1C105Z	CHIP C 1.0UF Z		
C478			C92-0507-05	CHIP TAN 4.7UF 6.3WV		
C479			CK73FB1E103K	CHIP C 0.01UF K		
C480, 481			CK73FF1C105Z	CHIP C 1.0UF Z		
C482			CK73FB1H563K	CHIP C 0.056UF K		
C483			C92-0559-05	CHIP TAN 6.8UF 6.3WV		
C601-606			CK73FB1E103K	CHIP C 0.01UF K		
TC1			C05-0371-05	TRIM CAP 10PF		
A1 ,2			E72-0405-04	TERMINAL BOARD		
CN1		*	E40-5637-05	FLAT CABLE CONNECTOR(19P)		
CN2			E40-3237-05	PIN CONNECTOR ASSY(2P:SP)		
CN201			E40-3299-05	PIN CONNECTOR ASSY(2P:FAN)		
CN203			E40-5498-05	FLAT CABLE CONNECTOR(21P)		
CN401		*	E40-5638-05	FLAT CABLE CONNECTOR(21P)		
CN402		*	E40-5639-05	FLAT CABLE CONNECTOR(19P)		
CN403		*	E40-5652-25	PIN CONNECTOR ASSY(4P)		
CN404			E40-5618-05	FLAT CABLE CONNECTOR(8P)		
CN601-603			E40-5409-05	PIN CONNECTOR ASSY(5P)		
J1 ,2			E11-0448-05	PHONE JACK		
J401			E08-0877-05	RECTANGULAR RECEPTACLE		
J402		*	E56-0404-05	CYLINDRICAL RECEPTACLE(6P)		
W1 ,2		*	E37-0458-05	CABLE	KP	
-			F10-2028-04	SHIELDING CASE		

L:Scandinavia

K:USA

P:Canada

Y:PX(Far East, Hawaii)

T:England

E:Europe

Y:AAFES(Europe)

X:Australia

M:Other Areas

TM-733A : K, P, M, M2, M3, M4

TM-733E : E, E2, E3, E9

⚠ indicates safety critical components.

PARTS LIST

× New Parts

Parts without Parts No. are not supplied.

Les articles non mentionnés dans le Parts No. ne sont pas fournis.

Teile ohne Parts No. werden nicht geliefert.

TX-RX UNIT (X57-436X-XX)

Ref. No. 参照番号	Address 位置	New Parts 新	Parts No. 部品番号	Description 部品名 / 規格	Desti- nation 仕 向	Re- marks 備考
F201		*	F53-0108-05	FUSE (1.8A)		
F202		*	F53-0110-05	FUSE (1.2A)		
F401		*	F53-0110-05	FUSE (1.2A)		
100	3C	*	G02-0760-04	FLAT SPRING		
-		*	G13-1438-24	CUSHION(LITHIUM BATT)		
-			J30-0545-05	SPACER(CRYSTAL RESONATOR)		
CD1			L79-1013-05	FILTER(455KHZ)		
CD201			L79-1013-05	FILTER(455KHZ)		
CF1		*	L72-0400-05	CERAMIC FILTER(455KHZ)		
CF201		*	L72-0400-05	CERAMIC FILTER(455KHZ)		
L2			L40-1885-34	SMALL FIXED INDUCTOR(180NH)		
L3			L40-2785-34	SMALL FIXED INDUCTOR(270NH)		
L4		*	L34-4343-05	COIL		
L5		*	L34-4344-05	COIL		
L6			L40-1005-34	SMALL FIXED INDUCTOR(10UH)		
L7		*	L34-4344-05	COIL		
L8			L40-1585-34	SMALL FIXED INDUCTOR(150NH)		
L10		*	L34-4345-05	COIL		
L11			L40-1095-34	SMALL FIXED INDUCTOR(1UH)		
L12			L92-0131-05	CORE		
L13 , 14			L40-1871-34	SMALL FIXED INDUCTOR(18NH)		
L15			L40-1271-34	SMALL FIXED INDUCTOR(12NH)		
L16			L40-1071-34	SMALL FIXED INDUCTOR(10NH)		
L17			L40-3371-34	SMALL FIXED INDUCTOR(33NH)		
L18			L40-2271-34	SMALL FIXED INDUCTOR(22NH)		
L19			L40-1005-34	SMALL FIXED INDUCTOR(107U)		
L20			L40-3385-34	SMALL FIXED INDUCTOR(330NH)		
L21			L40-8271-34	SMALL FIXED INDUCTOR(82NH)		
L22			L40-4785-34	SMALL FIXED INDUCTOR(470NH)		
L23			L34-1239-05	COIL (10.5T)		
L24			L34-0895-05	COIL (6T)		
L25			L34-0742-05	COIL (5T)		
L26			L34-1239-05	COIL (10.5T)		
L27 , 28			L34-0499-05	COIL (4T)		
L29			L34-0742-05	COIL (5T)		
L201			L40-4771-34	SMALL FIXED INDUCTOR(47NH)		
L202			L40-1871-34	SMALL FIXED INDUCTOR(18NH)		
L203			L79-1037-05	FILTER(435MHZ)	MM2M3	
L203			L79-1037-05	FILTER(435MHZ)	M4EE2	
L203			L79-1037-05	FILTER(435MHZ)	E3E9	
L203			L79-1038-05	FILTER(445MHZ)	KP	
L204		*	L40-3971-34	SMALL FIXED INDUCTOR(39NH)		
L205			L79-1037-05	FILTER(435MHZ)	MM2M3	
L205			L79-1037-05	FILTER(435MHZ)	M4EE2	
L205			L79-1037-05	FILTER(435MHZ)	E3E9	
L205			L79-1038-05	FILTER(445MHZ)	KP	
L211			L40-1095-34	SMALL FIXED INDUCTOR(1UH)		
L212			L40-3371-34	SMALL FIXED INDUCTOR(33NH)		
L213			L40-2271-34	SMALL FIXED INDUCTOR(22NH)		
L214		*	L34-4346-05	COIL		
L215			L40-3985-34	SMALL FIXED INDUCTOR(390NH)		
L217			L40-1071-34	SMALL FIXED INDUCTOR(10NH)		
L218			L40-1095-34	SMALL FIXED INDUCTOR(1UH)		

L:Scandinavia

K:USA

P:Canada

Y:PX(Far East, Hawaii)

T:England

E:Europe

Y:AAFES(Europe)

X:Australia

M:Other Areas

TM-733A : K, P, M, M2, M3, M4

TM-733E : E, E2, E3, E9

⚠ indicates safety critical components.

PARTS LIST

× New Parts

Parts without **Parts No.** are not supplied.

Les articles non mentionnés dans le **Parts No.** ne sont pas fournis.

Teile ohne **Parts No.** werden nicht geliefert.

TX-RX UNIT (X57-436X-XX)

Ref. No. 参照番号	Address 位置	New Parts 新	Parts No. 部品番号	Description 部品名 / 規格	Desti- nation 仕 向	Re- marks 備考
L219			L40-1271-34	SMALL FIXED INDUCTOR(12NH)		
L220			L40-6871-34	SMALL FIXED INDUCTOR(68NH)		
L221, 222			L40-4771-34	SMALL FIXED INDUCTOR(47NH)		
L223			L40-1005-34	SMALL FIXED INDUCTOR(10UH)		
L230			L40-2771-34	SMALL FIXED INDUCTOR(27NH)		
L231			L34-1238-05	COIL (9.5T)		
L232			L34-1207-05	COIL (3.5T)		
L233, 234			L34-1185-05	COIL (2.5T)		
L235			L34-1226-05	COIL (1.5T)		
L236, 237			L34-1019-05	COIL (2.5T)		
L238, 239			L34-1052-05	COIL (1.5T)		
L241			L34-0742-05	COIL (5T)		
L243			L92-0131-05	CORE		
L244			L40-3371-34	SMALL FIXED INDUCTOR(33NH)		
L401			L92-0131-05	CORE		
X1			L77-1478-05	CRYSTAL RESONATOR(45.505MHZ)		
X2		*	L77-1570-05	CRYSTAL RESONATOR(12.8MHZ)		
X201			L77-1479-05	CRYSTAL RESONATOR(58.07MHZ)		
X401			L78-0089-05	RESONATOR (48KHZ)		
X402			L77-1397-05	CRYSTAL RESONATOR(4.19MHZ)		
XF1		*	L71-0443-05	CRYSTAL FILTER (45.050MHZ)		
XF201		*	L71-0447-05	CRYSTAL FILTER (58.525MHZ)		
CP401			R90-0711-05	MULTI-COMP		
CP402			R90-0714-05	MULTI-COMP 10KX4		
CP403			R90-0720-05	MULTI COMP 100K		
R1			RK73FB2A473J	CHIP R 47K J 1/10W		
R2			RK73FB2A101J	CHIP R 100 J 1/10W		
R3			RK73FB2A104J	CHIP R 100K J 1/10W		
R4			RK73FB2A274J	CHIP R 270K J 1/10W		
R5			RK73FB2A223J	CHIP R 22K J 1/10W		
R6			RK73FB2A123J	CHIP R 12K J 1/10W		
R7			RK73FB2A820J	CHIP R 82 J 1/10W		
R8			RK73FB2A103J	CHIP R 10K J 1/10W		
R9 , 10			RK73FB2A470J	CHIP R 47 J 1/10W		
R11			RK73FB2A103J	CHIP R 10K J 1/10W		
R12			RK73FB2A152J	CHIP R 1.5K J 1/10W		
R13			RK73FB2A104J	CHIP R 100K J 1/10W		
R14			RK73FB2A100J	CHIP R 10 J 1/10W		
R15			RK73FB2A103J	CHIP R 10K J 1/10W		
R16			RK73FB2A471J	CHIP R 470 J 1/10W		
R17 , 18			RK73FB2A104J	CHIP R 100K J 1/10W		
R19			RK73FB2A101J	CHIP R 100 J 1/10W		
R20			RK73FB2A104J	CHIP R 100K J 1/10W		
R21			RK73FB2A473J	CHIP R 47K J 1/10W		
R22			RK73FB2A472J	CHIP R 4.7K J 1/10W		
R23			RK73FB2A104J	CHIP R 100K J 1/10W		
R25			RK73FB2A470J	CHIP R 47 J 1/10W		
R26			RK73FB2A331J	CHIP R 330 J 1/10W		
R27			RK73FB2A102J	CHIP R 1.0K J 1/10W		
R28			RK73FB2A101J	CHIP R 100 J 1/10W		
R29			RK73FB2A331J	CHIP R 330 J 1/10W		
R30			RK73FB2A471J	CHIP R 470 J 1/10W		
R31			RK73FB2A101J	CHIP R 100 J 1/10W		
R32			RK73FB2A103J	CHIP R 10K J 1/10W		

L:Scandinavia

K:USA

P:Canada

Y:PX(Far East, Hawaii)

T:England

E:Europe

Y:AAFES(Europe)

X:Australia

M:Other Areas

TM-733A : K, P, M, M2, M3, M4

TM-733E : E, E2, E3, E9

△ indicates safety critical components.

PARTS LIST

× New Parts

Parts without Parts No. are not supplied.

Les articles non mentionnés dans le Parts No. ne sont pas fournis.

Teile ohne Parts No. werden nicht geliefert.

TX-RX UNIT (X57-436X-XX)

Ref. No. 参照番号	Address 位置	New Parts 新	Parts No. 部品番号	Description 部品名 / 規格	Desti- nation 仕 向	Re- marks 備考
R33			RK73FB2A473J	CHIP R 47K J 1/10W		
R34			RK73FB2A103J	CHIP R 10K J 1/10W		
R35			RK73FB2A221J	CHIP R 220 J 1/10W		
R37			RK73FB2A103J	CHIP R 10K J 1/10W		
R38			RK73FB2A104J	CHIP R 100K J 1/10W		
R39			RK73FB2A473J	CHIP R 47K J 1/10W		
R40			RK73FB2A154J	CHIP R 150K J 1/10W		
R41			RK73FB2A102J	CHIP R 1.0K J 1/10W		
R42			RK73FB2A101J	CHIP R 100 J 1/10W		
R43			RK73FB2A473J	CHIP R 47K J 1/10W		
R44			RK73FB2A470J	CHIP R 47 J 1/10W		
R45			RK73FB2A222J	CHIP R 2.2K J 1/10W		
R46			RK73FB2A273J	CHIP R 27K J 1/10W		
R47			RK73FB2A223J	CHIP R 22K J 1/10W		
R48			RK73FB2A182J	CHIP R 1.8K J 1/10W		
R49	-51		RK73FB2A103J	CHIP R 10K J 1/10W		
R52			RK73FB2A182J	CHIP R 1.8K J 1/10W		
R53			RK73FB2A273J	CHIP R 27K J 1/10W		
R54			RK73FB2A123J	CHIP R 12K J 1/10W		
R55			RK73FB2A682J	CHIP R 6.8K J 1/10W		
R56			RK73FB2A332J	CHIP R 3.3K J 1/10W		
R57			RK73FB2A182J	CHIP R 1.8K J 1/10W		
R58			RK73FB2A473J	CHIP R 47K J 1/10W		
R59			RK73FB2A223J	CHIP R 22K J 1/10W		
R60	,61		RK73FB2A4R7J	CHIP R 4.7 J 1/10W		
R62			RK73FB2A274J	CHIP R 270K J 1/10W		
R63			RK73FB2A473J	CHIP R 47K J 1/10W		
R64			RK73FB2A153J	CHIP R 15K J 1/10W		
R65			RK73FB2A474J	CHIP R 470K J 1/10W		
R66			RK73FB2A471J	CHIP R 470 J 1/10W		
R67			RK73FB2A473J	CHIP R 47K J 1/10W		
R68			RK73FB2A223J	CHIP R 22K J 1/10W		
R69	,70		RK73FB2A153J	CHIP R 15K J 1/10W		
R71			RK73FB2A472J	CHIP R 4.7K J 1/10W		
R72			RK73FB2A184J	CHIP R 180K J 1/10W		
R73	,74		R92-0670-05	CHIP R 0 ΩHM		
R75	-77		RK73FB2A223J	CHIP R 22K J 1/10W		
R78			RK73FB2A153J	CHIP R 15K J 1/10W		
R79			RK73FB2A104J	CHIP R 100K J 1/10W		
R80			RK73FB2A105J	CHIP R 1.0M J 1/10W		
R81			RK73FB2A471J	CHIP R 470 J 1/10W		
R82			RK73FB2A184J	CHIP R 180K J 1/10W		
R83			RK73FB2A103J	CHIP R 10K J 1/10W		
R84			RK73FB2A471J	CHIP R 470 J 1/10W		
R85	,86		RK73FB2A222J	CHIP R 2.2K J 1/10W		
R87			RK73FB2A220J	CHIP R 22 J 1/10W		
R88			RK73FB2A122J	CHIP R 1.2K J 1/10W		
R89	,90		R92-0670-05	CHIP R 0 ΩHM		
R91			RK73FB2A473J	CHIP R 47K J 1/10W		
R92			RK73FB2A471J	CHIP R 470 J 1/10W		
R93			RK73FB2A101J	CHIP R 100 J 1/10W		
R94			RK73FB2A223J	CHIP R 22K J 1/10W		
R95			RK73FB2A154J	CHIP R 150K J 1/10W		
R96			RK73FB2A470J	CHIP R 47 J 1/10W		
R97			R92-0685-05	CHIP R 22 J 1/2W		

L:Scandinavia

K:USA

P:Canada

Y:PX(Far East, Hawaii)

T:England

E:Europe

Y:AAFES(Europe)

X:Australia

M:Other Areas

TM-733A : K, P, M, M2, M3, M4
TM-733E : E, E2, E3, E9

△ indicates safety critical components.

PARTS LIST

× New Parts

Parts without **Parts No.** are not supplied.

Les articles non mentionnés dans le **Parts No.** ne sont pas fournis.

Teile ohne **Parts No.** werden nicht geliefert.

TX-RX UNIT (X57-436X-XX)

Ref. No. 参照番号	Address 位置	New Parts 新	Parts No. 部品番号	Description 部品名 / 規格	Desti- nation 仕 向	Re- marks 備考
R98			RK73FB2A821J	CHIP R 820 J 1/10W		
R99			RK73FB2A5R6J	CHIP R 5.6 J 1/10W		
R100			RK73FB2A821J	CHIP R 820 J 1/10W		
R101			R92-1213-05	CARBON 100 J 1/2W		
R102, 103			RK73FB2A223J	CHIP R 22K J 1/10W		
R104			RK73FB2A220J	CHIP R 22 J 1/10W		
R105			RK73FB2A471J	CHIP R 470 J 1/10W		
R107			RK73FB2A471J	CHIP R 470 J 1/10W		
R108			RK73FB2A182J	CHIP R 1.8K J 1/10W		
R109			RK73FB2A151J	CHIP R 150 J 1/10W		
R110			RK73FB2A220J	CHIP R 22 J 1/10W		
R111			R92-0670-05	CHIP R 0 OHM		
R201			RK73FB2A104J	CHIP R 100K J 1/10W		
R202			RK73FB2A223J	CHIP R 22K J 1/10W		
R203			RK73FB2A151J	CHIP R 150 J 1/10W		
R204			RK73FB2A101J	CHIP R 100 J 1/10W		
R205			RK73FB2A470J	CHIP R 47 J 1/10W		
R206			RK73FB2A220J	CHIP R 22 J 1/10W		
R207			RK73FB2A222J	CHIP R 2.2K J 1/10W		
R208			RK73FB2A101J	CHIP R 100 J 1/10W		
R209			RK73FB2A104J	CHIP R 100K J 1/10W		
R210			RK73FB2A101J	CHIP R 100 J 1/10W		
R211			RK73FB2A332J	CHIP R 3.3K J 1/10W		
R213			RK73FB2A470J	CHIP R 47 J 1/10W		
R214			RK73FB2A223J	CHIP R 22K J 1/10W		
R215, 216			RK73FB2A102J	CHIP R 1.0K J 1/10W		
R217			RK73FB2A221J	CHIP R 220 J 1/10W		
R218			RK73FB2A102J	CHIP R 1.0K J 1/10W		
R219			RK73FB2A470J	CHIP R 47 J 1/10W		
R220			RK73FB2A221J	CHIP R 220 J 1/10W		
R221			RK73FB2A151J	CHIP R 150 J 1/10W		
R222			RK73FB2A334J	CHIP R 330K J 1/10W		
R223			RK73FB2A102J	CHIP R 1.0K J 1/10W		
R224			RK73FB2A103J	CHIP R 10K J 1/10W		
R225			RK73FB2A221J	CHIP R 220 J 1/10W		
R226			RK73FB2A104J	CHIP R 100K J 1/10W		
R227			RK73FB2A473J	CHIP R 47K J 1/10W		
R228			RK73FB2A101J	CHIP R 100 J 1/10W		
R229			RK73FB2A154J	CHIP R 150K J 1/10W		
R230			RK73FB2A102J	CHIP R 1.0K J 1/10W		
R231			RK73FB2A470J	CHIP R 47 J 1/10W		
R232			RK73FB2A223J	CHIP R 22K J 1/10W		
R233			RK73FB2A682J	CHIP R 6.8K J 1/10W		
R234, 235			RK73FB2A101J	CHIP R 100 J 1/10W		
R236			RK73FB2A470J	CHIP R 47 J 1/10W		
R237			RK73FB2A223J	CHIP R 22K J 1/10W		
R238			RK73FB2A472J	CHIP R 4.7K J 1/10W		
R239			RK73FB2A470J	CHIP R 47 J 1/10W		
R240			RK73FB2A220J	CHIP R 22 J 1/10W		
R241			RK73FB2A473J	CHIP R 47K J 1/10W		
R242			RK73FB2A223J	CHIP R 22K J 1/10W		
R243, 244			RK73FB2A103J	CHIP R 10K J 1/10W		
R245			RK73FB2A182J	CHIP R 1.8K J 1/10W		
R246			RK73FB2A103J	CHIP R 10K J 1/10W		
R247			RK73FB2A182J	CHIP R 1.8K J 1/10W		

L:Scandinavia

K:USA

P:Canada

Y:PX(Far East, Hawaii)

T:England

E:Europe

Y:AAFES(Europe)

X:Australia

M:Other Areas

TM-733A : K, P, M, M2, M3, M4
TM-733E : E, E2, E3, E9

 indicates safety critical components.

PARTS LIST

× New Parts

Parts without Parts No. are not supplied.

Les articles non mentionnés dans le Parts No. ne sont pas fournis.

Teile ohne Parts No. werden nicht geliefert.

TX-RX UNIT (X57-436X-XX)

Ref. No. 参照番号	Address 位置	New Parts 新	Parts No. 部品番号	Description 部品名 / 規格	Desti- nation 仕 向	Re- marks 備考
R248			RK73FB2A273J	CHIP R 27K J 1/10W		
R249			RK73FB2A123J	CHIP R 12K J 1/10W		
R250			RK73FB2A332J	CHIP R 3.3K J 1/10W		
R251			RK73FB2A682J	CHIP R 6.8K J 1/10W		
R252			RK73FB2A182J	CHIP R 1.8K J 1/10W		
R253-255			RK73FB2A223J	CHIP R 22K J 1/10W		
R256			RK73FB2A474J	CHIP R 470K J 1/10W		
R257			R92-0670-05	CHIP R 0 ΩHM		
R262, 263			R92-0670-05	CHIP R 0 ΩHM		
R266			RK73FB2A152J	CHIP R 1.5K J 1/10W		
R267			RK73FB2A221J	CHIP R 220 J 1/10W		
R268			RK73FB2A222J	CHIP R 2.2K J 1/10W		
R269			RK73FB2A103J	CHIP R 10K J 1/10W		
R270			RK73FB2A471J	CHIP R 470 J 1/10W		
R271			R92-0685-05	CHIP R 22 J 1/2W		
R272			R92-0670-05	CHIP R 0 ΩHM		
R273			RK73FB2A102J	CHIP R 1.0K J 1/10W		
R274			RK73FB2A222J	CHIP R 2.2K J 1/10W		
R275			RK73FB2A272J	CHIP R 2.7K J 1/10W		
R276			RK73FB2A154J	CHIP R 150K J 1/10W		
R277			R92-0699-05	CHIP R J 1/2W		
R279			R92-0670-05	CHIP R 0 ΩHM		
R282			R92-0679-05	CHIP R 0 ΩHM		
R283			R92-1214-05	CHIP R 120 J 1/2W		
R284, 285			RK73FB2A103J	CHIP R 10K J 1/10W		
R287			RK73FB2A471J	CHIP R 470 J 1/10W		
R288			RK73FB2A103J	CHIP R 10K J 1/10W		
R290			RK73FB2A473J	CHIP R 47K J 1/10W		
R291			RK73FB2A184J	CHIP R 180K J 1/10W		
R292			RK73FB2A102J	CHIP R 1.0K J 1/10W		
R293			RK73FB2A151J	CHIP R 150 J 1/10W		
R401			RK73FB2A103J	CHIP R 10K J 1/10W		
R402			RK73FB2A224J	CHIP R 220K J 1/10W		
R403			RK73FB2A473J	CHIP R 47K J 1/10W		
R404			RK73FB2A682J	CHIP R 6.8K J 1/10W		
R405			R92-0670-05	CHIP R 0 ΩHM		
R407			R92-0670-05	CHIP R 0 ΩHM		
R408			RK73FB2A472J	CHIP R 4.7K J 1/10W		
R409			RK73FB2A470J	CHIP R 47 J 1/10W		
R410			R92-0670-05	CHIP R 0 ΩHM	MEE3E9	
R411			R92-0670-05	CHIP R 0 ΩHM	EE2E3	
R411			R92-0670-05	CHIP R 0 ΩHM	E9	
R412			R92-0670-05	CHIP R 0 ΩHM	KP	
R412			R92-0670-05	CHIP R 0 ΩHM	MM2M3	
R413			R92-0670-05	CHIP R 0 ΩHM	M4	
R414			R92-0670-05	CHIP R 0 ΩHM	KPM4	
R414			R92-0670-05	CHIP R 0 ΩHM	EE3E9	
R415			RK73FB2A274J	CHIP R 270K J 1/10W		
R417			RK73FB2A182J	CHIP R 1.8K J 1/10W		
R418			RK73FB2A473J	CHIP R 47K J 1/10W		
R419			RK73FB2A224J	CHIP R 220K J 1/10W		
R420			RK73FB2A392J	CHIP R 3.9K J 1/10W		
R421			RK73FB2A102J	CHIP R 1.0K J 1/10W		
R422			RK73FB2A103J	CHIP R 10K J 1/10W		
R423, 424			RK73FB2A102J	CHIP R 1.0K J 1/10W		

L:Scandinavia

K:USA

P:Canada

Y:PX(Far East, Hawaii)

T:England

E:Europe

Y:AAFES(Europe)

X:Australia

M:Other Areas

TM-733A : K, P, M, M2, M3, M4

TM-733E : E, E2, E3, E9

⚠ indicates safety critical components.

PARTS LIST

× New Parts

Parts without **Parts No.** are not supplied.

Les articles non mentionnés dans le **Parts No.** ne sont pas fournis.

Teile ohne **Parts No.** werden nicht geliefert.

TX-RX UNIT (X57-436X-XX)

Ref. No. 参照番号	Address 位置	New Parts 新	Parts No. 部品番号	Description 部品名 / 規格	Desti- nation 仕 向	Re- marks 備考
R425			RK73FB2A224J	CHIP R 220K J 1/10W		
R427			RK73FB2A102J	CHIP R 1.0K J 1/10W		
R428			R92-0670-05	CHIP R 0 ΩHM		
R429			RK73FB2A152J	CHIP R 1.5K J 1/10W		
R432			RK73FB2A473J	CHIP R 47K J 1/10W		
R433			RK73FB2A103J	CHIP R 10K J 1/10W		
R434			RK73FB2A393J	CHIP R 39K J 1/10W		
R435			RK73FB2A103J	CHIP R 10K J 1/10W		
R436			RK73FB2A102J	CHIP R 1.0K J 1/10W		
R437			RK73FB2A824J	CHIP R 820K J 1/10W		
R438			RK73FB2A562J	CHIP R 5.6K J 1/10W		
R439			RK73FB2A273J	CHIP R 27K J 1/10W		
R440			RK73FB2A274J	CHIP R 270K J 1/10W		
R441			RK73FB2A474J	CHIP R 470K J 1/10W		
R442-444			RK73FB2A102J	CHIP R 1.0K J 1/10W		
R446			RK73FB2A473J	CHIP R 47K J 1/10W		
R447, 448			R92-0670-05	CHIP R 0 ΩHM		
R449			RK73FB2A473J	CHIP R 47K J 1/10W		
R450, 451			RK73FB2A472J	CHIP R 4.7K J 1/10W		
R452			RK73FB2A223J	CHIP R 22K J 1/10W		
R453			RK73FB2A472J	CHIP R 4.7K J 1/10W		
R454-458			RK73FB2A473J	CHIP R 47K J 1/10W		
R459, 460			RK73FB2A472J	CHIP R 4.7K J 1/10W		
R461			RK73FB2A103J	CHIP R 10K J 1/10W		
R462			RK73FB2A104J	CHIP R 100K J 1/10W		
R463			RK73FB2A473J	CHIP R 47K J 1/10W		
R466			RK73FB2A104J	CHIP R 100K J 1/10W	EE3E9	
R467			RK73FB2A103J	CHIP R 10K J 1/10W		
R468			RK73FB2A104J	CHIP R 100K J 1/10W		
R470			RK73FB2A472J	CHIP R 4.7K J 1/10W		
R471			RK73FB2A684J	CHIP R 680K J 1/10W		
R472			RK73FB2A392J	CHIP R 3.9K J 1/10W		
R474			RK73FB2A472J	CHIP R 4.7K J 1/10W		
R475			RK73FB2A684J	CHIP R 680K J 1/10W		
R476			RK73FB2A392J	CHIP R 3.9K J 1/10W		
R477			R92-0670-05	CHIP R 0 ΩHM		
R478			RK73FB2A153J	CHIP R 15K J 1/10W		
R480			RK73FB2A153J	CHIP R 15K J 1/10W		
R481			RK73FB2A101J	CHIP R 100 J 1/10W		
R482			RK73FB2A105J	CHIP R 1.0M J 1/10W		
R484, 485			RK73FB2A473J	CHIP R 47K J 1/10W		
R486			RK73FB2A472J	CHIP R 4.7K J 1/10W		
R487			RK73FB2A103J	CHIP R 10K J 1/10W		
R488			RK73FB2A102J	CHIP R 1.0K J 1/10W		
R489			RK73FB2A563J	CHIP R 56K J 1/10W		
R490-492			RK73FB2A473J	CHIP R 47K J 1/10W		
R493, 494			RK73FB2A102J	CHIP R 1.0K J 1/10W		
R495			RK73FB2A472J	CHIP R 4.7K J 1/10W		
R496			RK73FB2A102J	CHIP R 1.0K J 1/10W		
R497			RK73FB2A474J	CHIP R 470K J 1/10W		
R498			RK73FB2A103J	CHIP R 10K J 1/10W		
R500			RK73FB2A273J	CHIP R 27K J 1/10W		
R501			RK73FB2A224J	CHIP R 220K J 1/10W		
R503			RK73FB2A102J	CHIP R 1.0K J 1/10W		
R504			RK73FB2A472J	CHIP R 4.7K J 1/10W		

L:Scandinavia

Y:PX(Far East, Hawaii)

Y:AAFES(Europe)

K:USA

T:England

X:Australia

P:Canada

E:Europe

M:Other Areas

TM-733A : K, P, M, M2, M3, M4

TM-733E : E, E2, E3, E9

⚠ indicates safety critical components.

PARTS LIST

× New Parts

Parts without Parts No. are not supplied.

Les articles non mentionnés dans le Parts No. ne sont pas fournis.

Teile ohne Parts No. werden nicht geliefert.

TX-RX UNIT (X57-436X-XX)

Ref. No. 参照番号	Address 位置	New Parts 新	Parts No. 部品番号	Description 部品名 / 規格	Desti- nation 仕向	Re- marks 備考
R505			RK73FB2A272J	CHIP R 2.7K J 1/10W		
R506			RK73FB2A473J	CHIP R 47K J 1/10W		
R507			RK73FB2A103J	CHIP R 10K J 1/10W		
R508, 509			RK73FB2A102J	CHIP R 1.0K J 1/10W		
R510			RK73FB2A392J	CHIP R 3.9K J 1/10W	MM2M3	
R510			RK73FB2A392J	CHIP R 3.9K J 1/10W	M4E	
R510			RK73FB2A562J	CHIP R 5.6K J 1/10W	E2E3E9	
R511			RK73FB2A102J	CHIP R 1.0K J 1/10W	EE2E3	
R511			RK73FB2A222J	CHIP R 2.2K J 1/10W	M4E9	
R512			RK73FB2A184J	CHIP R 180K J 1/10W		
R513			RK73FB2A224J	CHIP R 220K J 1/10W		
R514			RK73FB2A103J	CHIP R 10K J 1/10W		
R515			RK73FB2A334J	CHIP R 330K J 1/10W		
R516			RK73FB2A561J	CHIP R 560 J 1/10W		
R517			RK73FB2A394J	CHIP R 390K J 1/10W		
R518			RK73FB2A333J	CHIP R 33K J 1/10W		
R519			RK73FB2A473J	CHIP R 47K J 1/10W		
R520			RK73FB2A224J	CHIP R 220K J 1/10W		
R521-523			RK73FB2A823J	CHIP R 82K J 1/10W		
R524			RK73FB2A472J	CHIP R 4.7K J 1/10W		
R525			RK73FB2A151J	CHIP R 150 J 1/10W		
R526			RK73FB2A102J	CHIP R 1.0K J 1/10W		
R527			RK73FB2A393J	CHIP R 39K J 1/10W		
R528			RK73FB2A474J	CHIP R 470K J 1/10W		
R529			RK73FB2A103J	CHIP R 10K J 1/10W		
R530			RK73FB2A823J	CHIP R 82K J 1/10W		
R531			RK73FB2A103J	CHIP R 10K J 1/10W		
R532			RK73FB2A473J	CHIP R 47K J 1/10W		
R533			RK73FB2A224J	CHIP R 220K J 1/10W		
R534			RK73FB2A103J	CHIP R 10K J 1/10W		
R535			RK73FB2A393J	CHIP R 39K J 1/10W		
R536			RK73FB2A563J	CHIP R 56K J 1/10W		
R537			RK73FB2A223J	CHIP R 22K J 1/10W		
R538			RK73FB2A273J	CHIP R 27K J 1/10W		
R540			RK73FB2A224J	CHIP R 220K J 1/10W		
R541			RK73FB2A102J	CHIP R 1.0K J 1/10W		
R542-548			RK73FB2A182J	CHIP R 1.8K J 1/10W		
R549			RK73FB2A103J	CHIP R 10K J 1/10W		
R550			RK73FB2A473J	CHIP R 47K J 1/10W		
R551			RK73FB2A472J	CHIP R 4.7K J 1/10W	EE2E3	
R551			RK73FB2A472J	CHIP R 4.7K J 1/10W	E9	
R552, 553			RK73FB2A103J	CHIP R 10K J 1/10W		
R554			RK73FB2A3R3J	CHIP R 3.3 J 1/10W		
VR1, 2			R12-6719-05	TRIM POT 100K		
VR3			R12-6713-05	TRIM POT 10K		
VR4			R12-6717-05	TRIM POT 47K		
VR201			R12-6719-05	TRIM POT 100K		
VR202			R12-6717-05	TRIM POT 47K		
VR203, 204			R12-6711-05	TRIM POT 4.7K		
VR601, 602			R23-9407-05	POTENTIOMETER 50K		
TS1			S59-0444-05	THERMAL SWITCH(90°C)		
D1 -5			MA360	DIORD		
D6			DAN235K	DIORD		
D7		*	DTZ5.6(A)	DIORD		

L:Scandinavia

K:USA

P:Canada

Y:PX(Far East, Hawaii)

T:England

E:Europe

Y:AAFES(Europe)

X:Australia

M:Other Areas

TM-733A : K, P, M, M2, M3, M4
TM-733E : E, E2, E3, E9

△ indicates safety critical components.

PARTS LIST

× New Parts

Parts without **Parts No.** are not supplied.

Les articles non mentionnés dans le **Parts No.** ne sont pas fournis.

Teile ohne **Parts No.** werden nicht geliefert.

TX-RX UNIT (X57-436X-XX)

Ref. No. 参照番号	Address 位置	New Parts 新	Parts No. 部品番号	Description 部品名 / 規格	Desti- nation 仕 向	Re- marks 備考
D8			DAN202U	DIORD		
D9			1SS226	DIORD		
D10			DAN235K	DIORD		
D11			DAN202U	DIORD		
D12			1SS181	DIORD		
D13			MI407	DIORD		
D14			MI308	DIORD		
D15 ,16			1SS226	DIORD		
D17			MA360	DIORD		
D18 ,19			MA110	DIORD		
D201			1SV128	DIORD		
D202			DAN202U	DIORD		
D203			MA716	DIORD		
D204			MA77	DIORD		
D205			MA862	DIORD		
D206,207			DAN202U	DIORD		
D210			MA862	DIORD		
D211			1SS184	DIORD		
D212			DAN202U	DIORD		
D213			MI407	DIORD		
D214			MI809	DIORD		
D215,216			MA716	DIORD		
D217			DSA3A1	DIORD		
D401,402			MA110	DIORD		
D403,404			MA112	DIORD		
D405			DTZ7.5(B)	DIORD		
D406		*	DTZ3.0(A)	DIORD		
D407,408			MA112	DIORD		
D409			1SS226	DIORD		
D411			MA110	DIORD		
IC1			KCD04	HIC(FM IF)		
IC2			KCD05	HIC(AM IF)		
IC3			UPC1676G	IC(POWER AMP)		
IC4			XRU4066BCF	IC (or BU4066BCF)		
IC5			XRU4094BF	IC (or BU4094BF)		
IC6			LA4445	IC(2CHANNEL AF POWER AMP 5.5W)		
IC7			XRU4053BCF	IC (or BU4053BCF)		
IC8			XRU4094BF	IC (or (BU4094BF)		
IC9		*	KCH19	HIC		MM2M3
IC9		*	KCH19	HIC		M4EE2
IC9		*	KCH19	HIC		E3E9
IC9		*	KCH21	HIC		KP
IC10			KCB11	HIC(DRIVER)		
IC11			LA5010M	IC(LOW SATURATION REGULATOR)		
IC12			TC4S66F	IC(BILATERAL SWITCH)		
IC201			KCD04	HIC(FM IF)		
IC202		*	KCB28	HIC		MM2M3
IC202		*	KCB28	HIC		M4EE2
IC202		*	KCB28	HIC		E3E9
IC203			KCB27	HIC		
IC204			XRU4066BCF	IC (or BU4066BCF)		
IC205,206			XRU4094BF	IC (or BU4094BF)		
IC207		*	KCH20	HIC		
IC208			LA5010M	IC(LOW SATURATION REGULATOR)		
IC209			KCB14	HIC(DRIVER)		MM2M3

L:Scandinavia

K:USA

P:Canada

Y:PX(Far East, Hawaii)

T:England

E:Europe

Y:AAFES(Europe)

X:Australia

M:Other Areas

TM-733A : K, P, M, M2, M3, M4
TM-733E : E, E2, E3, E9

⚠ indicates safety critical components.

PARTS LIST

× New Parts

Parts without **Parts No.** are not supplied.

Les articles non mentionnés dans le **Parts No.** ne sont pas fournis.

Teile ohne **Parts No.** werden nicht geliefert.

TX-RX UNIT (X57-436X-XX)

Ref. No. 参照番号	Address 位置	New Parts 新	Parts No. 部品番号	Description 部品名 / 規格	Desti- nation 仕向	Re- marks 備考
IC209			KCB14	HIC(DRIVER)	M4EE2	
IC209			KCB14	HIC(DRIVER)	E3E9	
IC209		*	KCB20	HIC	KP	
IC210			KCC04	HIC(APC)		
IC211			MC7808CT	IC(VOLTAGE REGULATORS/ +8V)		
IC401		*	LC7387M	IC		
IC402			TC35219F	IC		
IC403		*	75518GF-186-3B9	IC(CPU)	MM2M3	
IC403		*	75518GF-186-3B9	IC(CPU)	M4EE2	
IC403		*	75518GF-186-3B9	IC(CPU)	E3E9	
IC403		*	75518GF-188-3B9	IC(CPU)	KP	
IC404			XRU4066BCF	IC (or BU4066BCF)		
IC405, 406			XRU4053BCF	IC (or BU4053BCF)		
IC407			MB87032PF	IC		
IC408			TA78L06F	IC		
IC409, 410			SC14S11F	IC (or TC4S11F)		
IC411			XRU4066BCF	IC (or BU4066BCF)		
IC412, 413			NJM4558E	IC(OP AMP)		
Q1		*	3SK241(R)	FET		
Q2			FMG1	TRANSISTOR		
Q3 , 4			3SK131(L)	FET		
Q5			DTC114EU	DIGITAL TRANSISTOR		
Q6			2SC4215(Y)	TRANSISTOR		
Q7			DTA123JU	DIGITAL TRANSISTOR		
Q8		*	DTC143EU	DIGITAL TRANSISTOR		
Q9			2SJ106(GR)	FET		
Q10			2SC4116(Y)	TRANSISTOR		
Q11 , 12			DTA123JU	DIGITAL TRANSISTOR		
Q13			3SK184(S)	FET		
Q14			DTC114EU	DIGITAL TRANSISTOR		
Q15			DTC144WU	DIGITAL TRANSISTOR		
Q16			2SA1362(Y)	TRANSISTOR		
Q17			2SB1119(S)	TRANSISTOR		
Q18 , 19			2SC4116(Y)	TRANSISTOR		
Q20			DTC114EU	DIGITAL TRANSISTOR		
Q21			2SK1824	FET		
Q22			2SK1399	FET		
Q23			UPA502T	IC(SWITCHING/MOS FET)		
Q24			2SK879(Y)	FET		
Q25			2SC4215(Y)	TRANSISTOR		
Q26			2SC4116(Y)	TRANSISTOR		
Q27			FMG1	TRANSISTOR		
Q28 , 29			2SC4116(Y)	TRANSISTOR		
Q30 , 31			DTC114EU	DIGITAL TRANSISTOR		
Q201		*	3SK241(R)	FET		
Q202			FMA5	TRANSISTOR		
Q203			DTA123JU	DIGITAL TRANSISTOR	MM2M3	
Q203			DTA123JU	DIGITAL TRANSISTOR	M4EE2	
Q203			DTA123JU	DIGITAL TRANSISTOR	E3E9	
Q204		*	3SK241(R)	FET		
Q205			DTC114EU	DIGITAL TRANSISTOR		
Q206			3SK184(S)	FET		
Q207			DTC114EK	DIGITAL TRANSISTOR		
Q208			2SC4215(Y)	TRANSISTOR		
Q209			2SJ106(GR)	FET		

L:Scandinavia

K:USA

P:Canada

Y:PX(Far East, Hawaii)

T:England

E:Europe

Y:AAFES(Europe)

X:Australia

M:Other Areas

TM-733A : K, P, M, M2, M3, M4
TM-733E : E, E2, E3, E9

 indicates safety critical components.

PARTS LIST

× New Parts

Parts without **Parts No.** are not supplied.

Les articles non mentionnes dans le **Parts No.** ne sont pas fournis.

Teile ohne **Parts No.** werden nicht geliefert.

TX-RX UNIT (X57-436X-XX)

Ref. No. 参照番号	Address 位置	New Parts 新	Parts No. 部品番号	Description 部品名 / 規格	Desti- nation 仕向	Re- marks 備考
Q210			2SC4116(Y)	TRANSISTOR		
Q211			2SC3356	TRANSISTOR		
Q212			3SK131(L)	FET		
Q213			DTC114EU	DIGITAL TRANSISTOR		
Q214			2SC4116(Y)	TRANSISTOR		
Q215			DTC144WU	DIGITAL TRANSISTOR		
Q216			2SA1362(Y)	TRANSISTOR		
Q217			2SC4116(Y)	TRANSISTOR		
Q218			2SB1119(S)	TRANSISTOR		
Q219			DTC114EU	DIGITAL TRANSISTOR		
Q220			DTA123JU	DIGITAL TRANSISTOR		
Q221-224			2SK1824	FET		
Q228			2SC4116(Y)	TRANSISTOR		
Q229			2SC3123	TRANSISTOR		
Q230			DTD143EK	DIGITAL TRANSISTOR		
Q231			FMG1	TRANSISTOR		
Q232			2SC4728(S)	TRANSISTOR		
Q233			2SB1302(S)	TRANSISTOR		
Q234			DTC114EU	DIGITAL TRANSISTOR		
Q236			2SC4215(Y)	TRANSISTOR		
Q401			DTC144EU	DIGITAL TRANSISTOR		
Q402, 403			2SC4116(Y)	TRANSISTOR		
Q404, 405			DTC114EU	DIGITAL TRANSISTOR		
Q406-408			2SC4116(Y)	TRANSISTOR		
Q409-412			2SK1824	TRANSISTOR		
Q413, 414			2SC4116(Y)	TRANSISTOR		
Q415			2SA1519	TRANSISTOR		
Q416			2SK1824	FET		
Q417			DTC114EU	DIGITAL TRANSISTOR		
Q418			2SC4116(Y)	TRANSISTOR		
Q420			2SC4116(Y)	TRANSISTOR		
Q421			DTC144EU	DIGITAL TRANSISTOR		
Q422			DTA123JU	DIGITAL TRANSISTOR		
Q423-425			2SC4116(Y)	TRANSISTOR		
Q426			DTC114EU	DIGITAL TRANSISTOR		
BA1			W09-0570-05	LITHIUM BATTERY(3V 7mAh)		
S601		*	W02-1822-05	ENCODER		

L:Scandinavia

Y:PX(Far East, Hawaii)

Y:AAFES(Europe)

K:USA

T:England

X:Australia

P:Canada

E:Europe

M:Other Areas

TM-733A : K, P, M, M2, M3, M4

TM-733E : E, E2, E3, E9

 indicates safety critical components.

PARTS LIST

× New Parts

Parts without Parts No. are not supplied.

Les articles non mentionnes dans le Parts No. ne sont pas fournis.

Teile ohne Parts No. werden nicht geliefert.

LCD ASSY (B38-070X-25)

LCD ASSY TEMPORARY UNIT

Ref. No. 参照番号	Address 位置	New Parts 新	Parts No. 部品番号	Description 部品名 / 規格	Desti- nation 仕向	Re- marks 備考
LCD ASSY (B38-070X-25) 8 : M4 9 : K, P, M, M2, M3, E, E2, E3, E9						
-		*	B10-1207-03	FRONT GLASS		
-		*	E29-1134-08	RUBBER CONNECTOR		
CN1		*	E40-5653-05	CONNECTOR (4 P)		
CN2 -4		*	E40-5392-05	CONNECTOR (5 P)		
-		*	G11-0718-08	SPACER		
-		*	J21-4445-08	METAL FRAME		
XT1			L77-1397-05	CRYSTAL RESONATOR(4.194304MHZ)		
SW1 -12			S70-0408-05	TACT SWICH		
D1			LFB01	DIORD		
D2			MA110	DIORD		
LED1 ,2		*	B30-2132-08	LED		
IC1			L78LR05B-FA	IC		
IC2 ,3			SC14S11F	IC (or TC4S11F)		
IC4		*	75336GC-075-3B9	IC(CPU)		
IC5		*	AT24C08N	IC		
IC6 ,7		*	NJU6432BF	IC		
LCD1		*	B38-0710-08	LCD ELEMENT	M4	
LCD1		*	B38-0711-08	LCD ELEMENT	KPMM2	
LCD1		*	B38-0711-08	LCD ELEMENT	M3EE2	
LCD1		*	B38-0711-08	LCD ELEMENT	E3E9	
PL1 -4			B30-0865-15	LAMP (6.3V 75mA)		
Q1		*	2SB1149(M)	TRANSISTOR		
Q2		*	2SC2712(Y)	TRANSISTOR		
Q3 ,4			2SA1162(Y)	TRANSISTOR		
LCD ASSY TEMPORARY UNIT						
C701			C92-0005-05	CHIP TAN 2.2UF 6.3WV		
C702			CK73GB1E103K	CHIP C 0.01UF K		
R701			RK73GB1J223J	CHIP R 22K J 1/16W		
R703			R92-1252-05	CHIP R 0 OHM 1/16W		
R704			RK73GB1J103J	CHIP R 10K J 1/16W		
R705			RK73GB1J333J	CHIP R 33K J 1/16W		
R706			RK73GB1J823J	CHIP R 82K J 1/16W		
R707			RK73GB1J563J	CHIP R 56K J 1/16W		
R708			RK73GB1J223J	CHIP R 22K J 1/16W		
R709			RK73GB1J103J	CHIP R 10K J 1/16W		
R710			RK73GB1J823J	CHIP R 82K J 1/16W		
R711			RK73GB1J333J	CHIP R 33K J 1/16W		
R712			R92-1252-05	CHIP R 0 OHM 1/16W		
R713			RK73GB1J563J	CHIP R 56K J 1/16W		
R715,716			R92-1252-05	CHIP R 0 OHM 1/16W		
IC701			NJM2903M	IC		
Q701,702			2SC4116(Y)	TRANSISTOR		

L:Scandinavia

K:USA

P:Canada

Y:PX(Far East, Hawaii)

T:England

E:Europe

Y:AAFES(Europe)

X:Australia

M:Other Areas

TM-733A : K, P, M, M2, M3, M4

TM-733E : E, E2, E3, E9

△ indicates safety critical components.

- A M2.6 x 6 (OC) BLK : N33-2606-45
- B M2.6 x 8 (Bi) BLK : N35-2608-45
- C M3 x 10 : N67-3010-46
- D : N80-2010-45
- E : N80-2610-45
- F M2.6 x 6 (Br-Tap) : N87-2606-46

Note that the washer may come off during disassembly

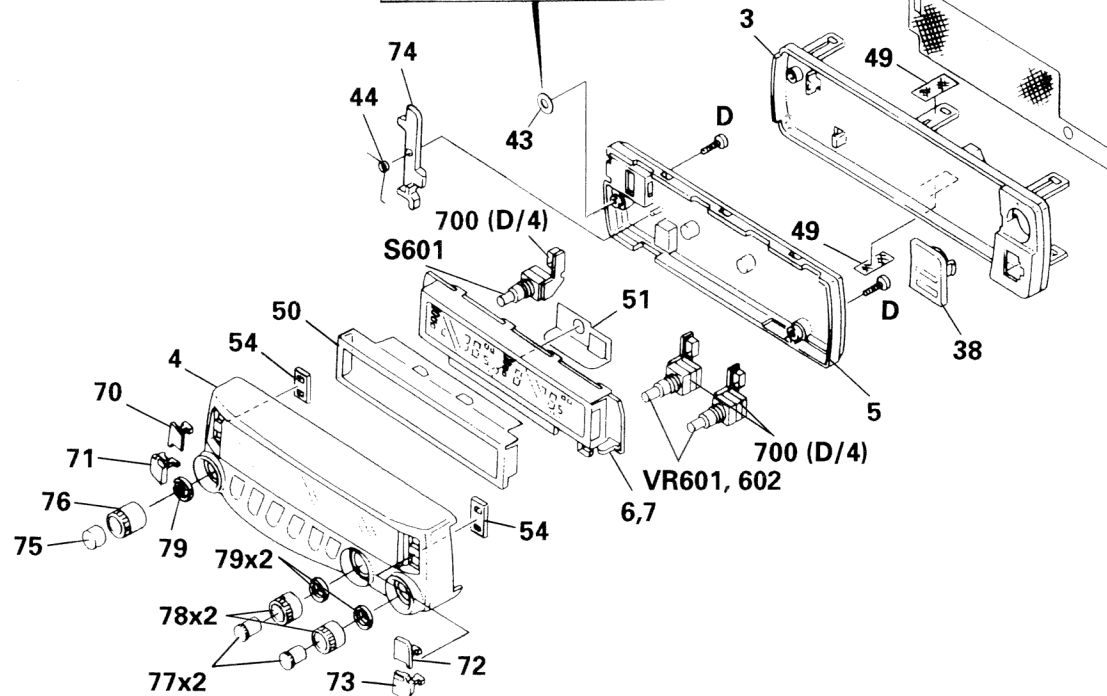
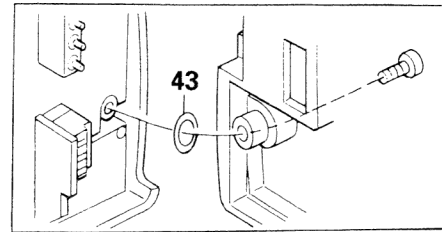

/E TM-733A/E

EXPLODED VIEW

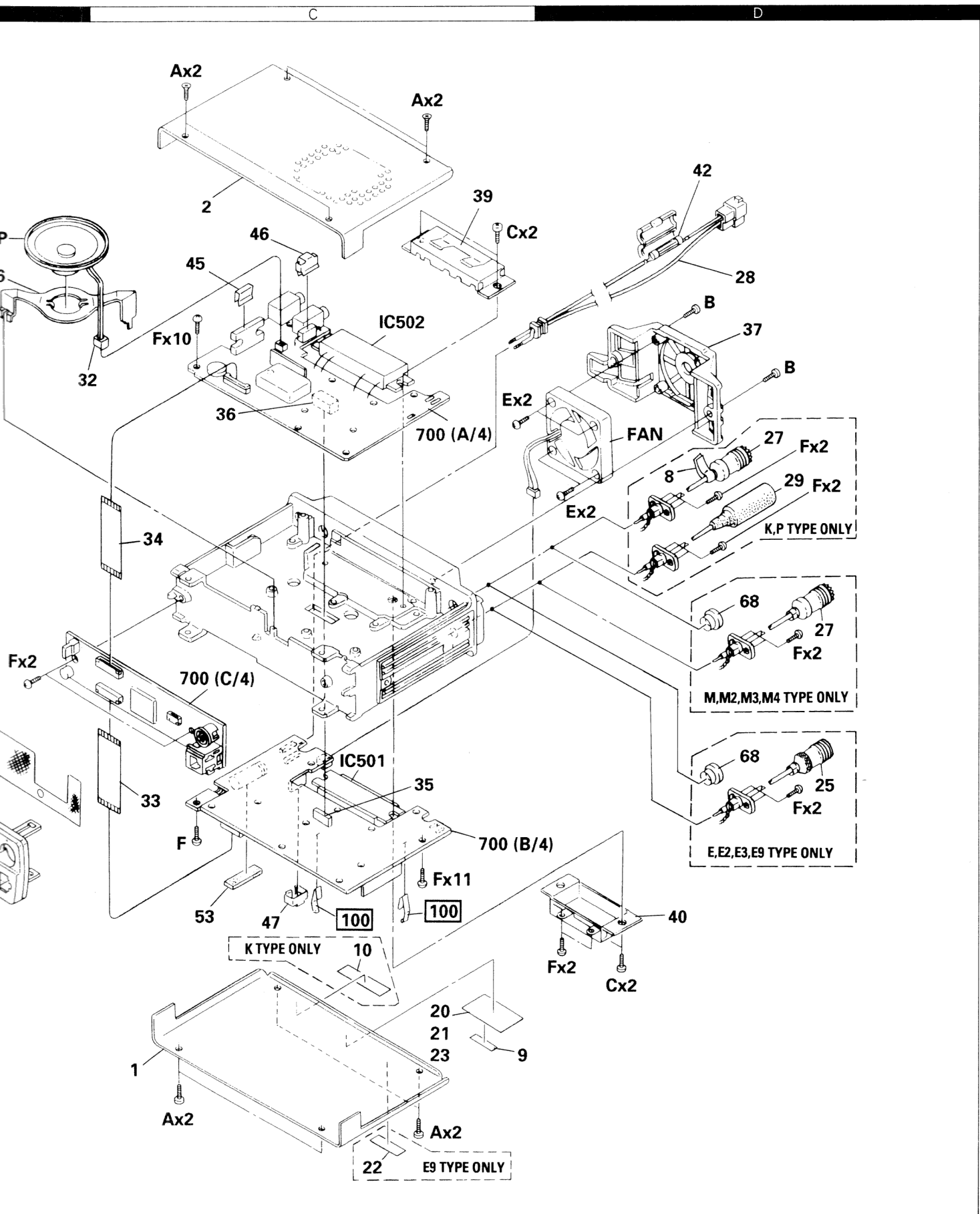

PACKING

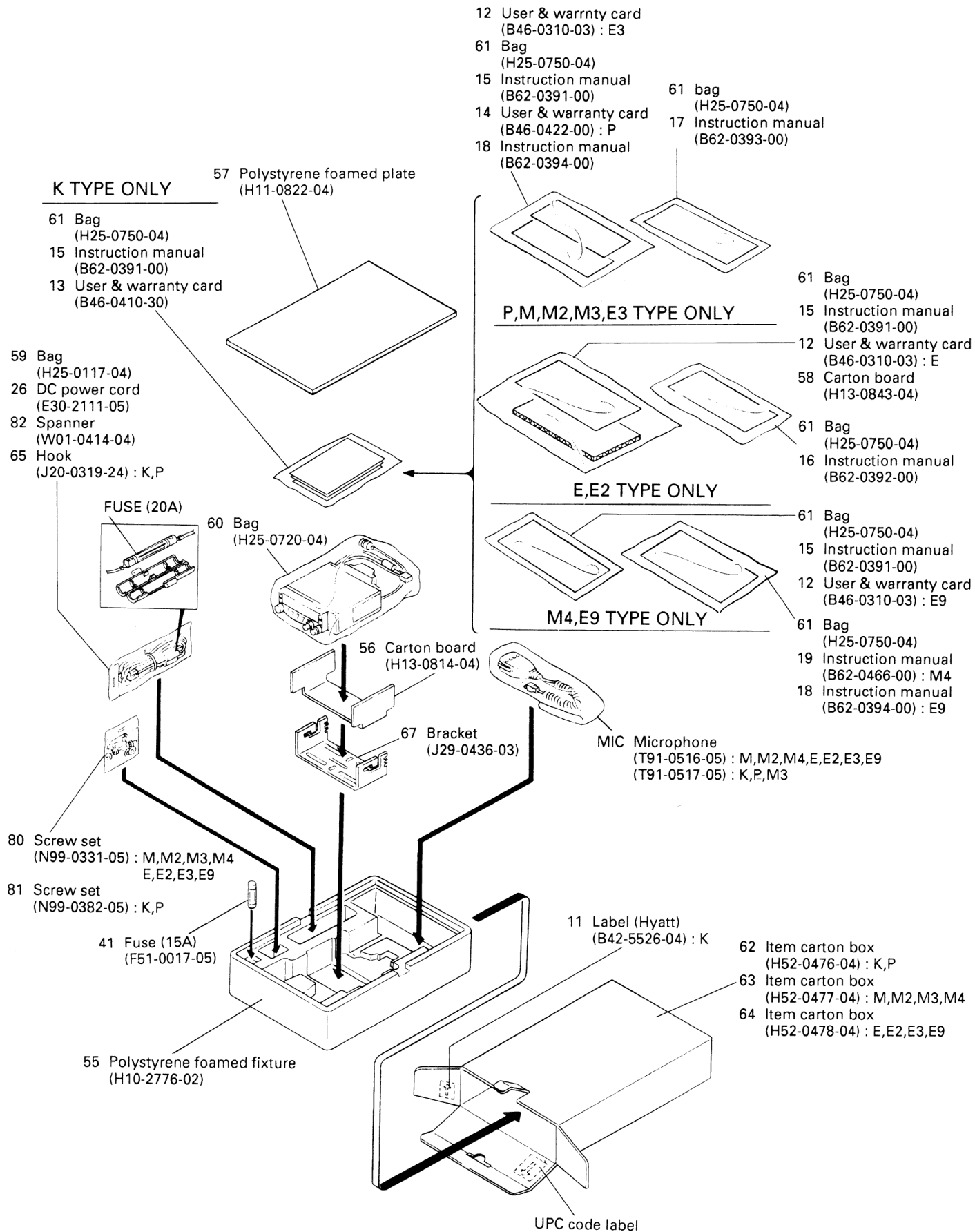

ADJUSTMENT

Measuring Equipment for Adjustment

1. Tester
Input impedance: High
2. RF valve voltmeter (RF V.M)
Input impedance: $1M\Omega$ or more, 2 pF or less
Voltage range: Full scale = 10mV to 300V
Measurable frequency range: up to 450MHz
3. Frequency counter (f. counter)
Input sensitivity: About 50mV
Measurable frequency: 450MHz or more
4. DC power supply
Voltage: Variable in the range 10 to 17V
Current: 13A or more
5. Power meter
Measurement power: 60W, 10W, 1W
Impedance: 50Ω
Measurable frequency: 450MHz
6. AF valve voltmeter (AF V.M)
Input impedance: $1M\Omega$ or more
Voltage range: Full scale = 1mV to 30V
Measurable frequency range: 50Hz to 10kHz
7. AF generator (AG)
Output frequency: 100Hz to 10kHz
Output voltage: 0.5mV to 1V
8. Line detector
Measurable frequency: 450MHz
9. Spectrum analyzer
Measurable frequency: 450MHz
10. Directional coupler
11. Oscilloscope
High sensitivity with horizontal input terminal
12. Standard signal generator (SSG)
The standard signal generator must be able to generate the 144 and 430MHz band frequencies and vary the amplitude and frequency.
Output: $0.1\mu V$ to greater than 1mV
13. Dummy load (for AF)
 8Ω , about 5W
14. Noise generator
The noise generator must be able to generate noise similar to ignition noise containing high-frequency components of 450MHz or more.
15. Sweep generator
The sweep generator must be able to sweep the 144 and 430MHz bands.
16. Tracking generator
17. Adjustment jig

Preparation

- Set the controls and switches to the positions listed below unless otherwise specified.

VOL control	Fully counterclockwise
SQL control	Fully counterclockwise
POWER switch	OFF
(For fixed stations)	OFF
DC power supply POWER switch	

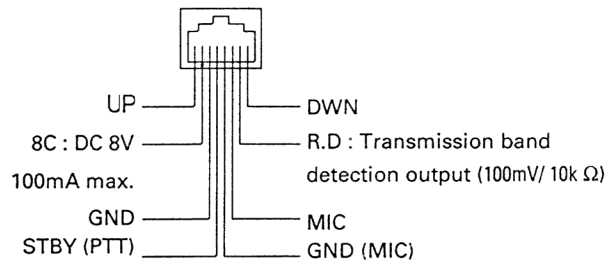

**Microphone socket
(as viewed from the front of the set)**

- Use an insulated rod, such as a plastic rod, for adjustment (especially for trimmers, coils, etc.).
- To protect the signal generator, never connect the microphone to the microphone socket when the receiver section is adjusted.
- Before the power cord is connected, make sure the power switch is off.
- The SSG output level in parentheses are displayed at the release end.
Without specification of SSG, standard modulation is applied (MOD : 1kHz, DEV : ± 3 kHz, AF output : 0.63V/8 Ω).
- See the instruction manual for transmit and receive operations.

ADJUSTMENT

Adjustment Jig (* : New parts)

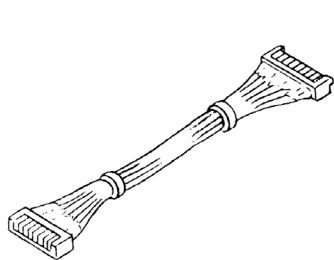

A Cable with connector (7 pin)
(Use with TM-732)

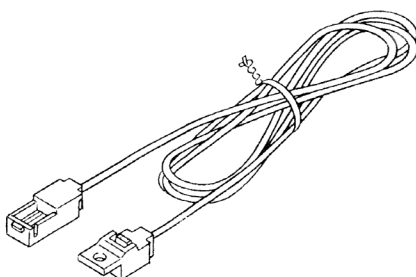

B Panel cable (3m)*
(E30-3189-05)

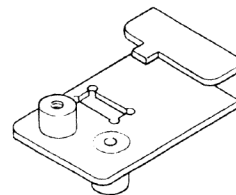

C Panel cable mounting hardware*
(J21-4475-04)

How to Use

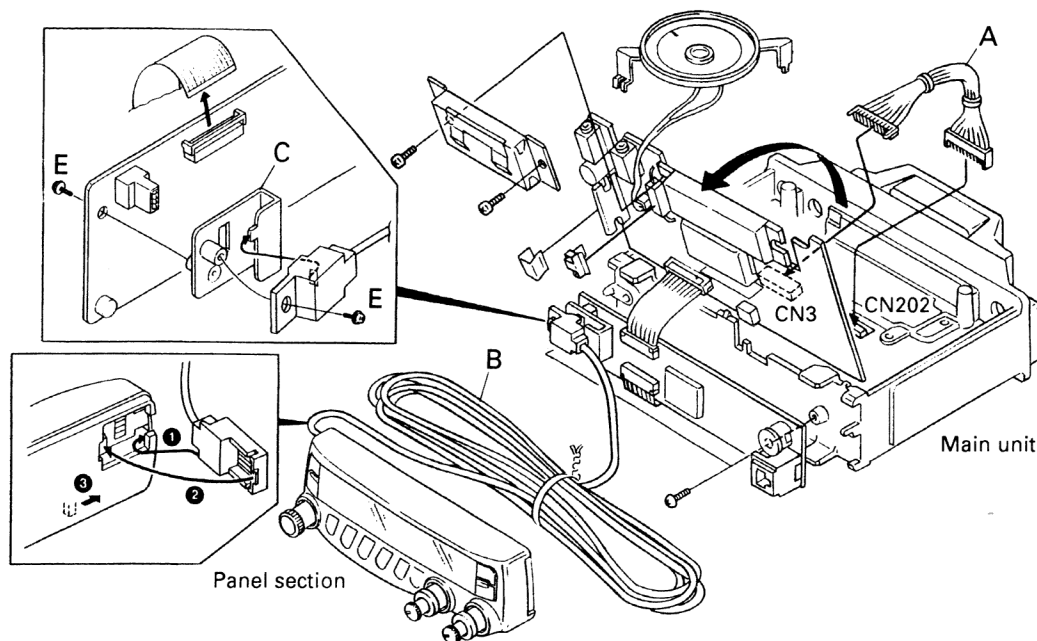

E: Screw (M2.6 x 6)
(N09-2241-05 etc.)

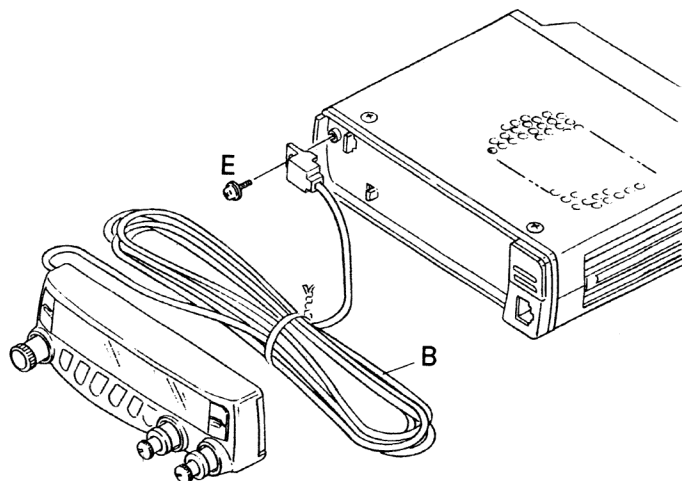

ADJUSTMENT

Method of Checking the Operation of the LCD Assembly

The display microcomputer has an Assembly mode function that is useful in checking for panel display and key operation faults. The function is also helpful in investigating problems or checking operation after a repair.

When the main unit and the panel are connected together in the normal way (or by using a separate cable), the operation of the microcomputer in the main unit can also be checked.

• Entering Assembly mode

Hold down the CALL and MUTE keys and press the PWR key. All LCD segments come on and Assembly mode is entered. (See the figure below.)

If the mode fails to be entered, DC power supply power goes off, then entering assembly mode again. To exit Assembly mode, press the PWR key again or DC power supply power goes off.

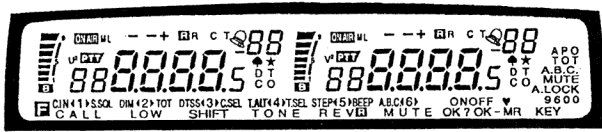

• Checking operation

1. Press the VFO/M>V key. **(This must always be done first.)**

The serial port is automatically checked.

- If it functions normally;
 - "F" and "80" are displayed. (See the figure below)
- If it does not function normally;
 - "1" or "2" is displayed.
 - ("1" : When SO is made low, SI does not go low.)
 - ("2" : When SO is made high, SI does not go high.)



2. Press the BAND SEL key. (Press the AF VOL control.)

"8d" and the function indicator appear.
(The left green LED lights.)

"8E" and the function indicator appear.
(The right green LED lights.)

3. Press the CONT SEL key.
"8A" and the function indicator appear.
4. Press the PM key.
"8b" and the "1" to "6" key indicators appear.
5. Press the MHz key.
"82" and the function indicator appear.
6. Press the CALL key.
"5" and "83" appear dimly. (Minimum intensity)
7. Press the LOW key.
"4" and "89" appear. (Intensity level 4: Dim)
8. Press the SHIFT (BELL) key.
"3" and "85" appear. (Intensity level 3: Slightly dim)
9. Press the TONE key.
"2" and "86" appear. (Intensity level 2)
10. Press the REV key.
"1" and "87" appear. (Intensity level 1: Strongest)
11. Press the MUTE key.
"22222" and "22" appear.
12. Press the F key.
Each time the F key is pressed, the 6 key function display changes in three levels.
13. Set the AF and SQL-VRs to minimum, then press the MR/M key.
"00" appears on the UHF-band frequency display and "00" appears on the memory channel display.

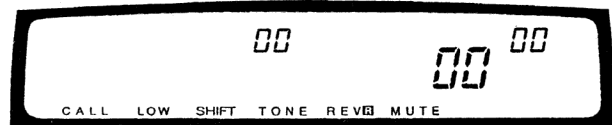

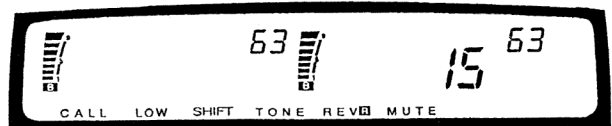

- When the tuning knob (encoder) is turned, the number changes in the range 00 to 15.
- When the AF VOL(V) control is turned, the VHF S meter changes.
- When the AF VOL(U) control is turned, the UHF S meter changes.
- When the SQ VOL(V) control is turned, the VHF MR channel display changes in the range 00 to 63.
- When the SQ VOL(U) control is turned, the UHF MR channel display changes in the range 00 to 63.

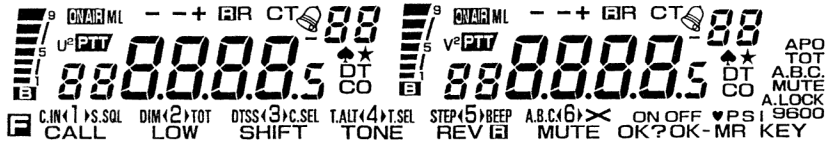

ADJUSTMENT

Common Section

Item	Condition	Measurement			Adjustment			Specifications/Remarks
		Test-equipment	Unit	Terminal	Unit	Parts	Method	
1. Setting	<p>1) Power voltage : DC 13.8V</p> <p>2) Check to all LCD lights on. While pushing CALL key and MUTE key, turn on POWER. Upon confirming that all have lit up, turn off POWER after pushing VFO key.</p> <p>3) Reset While pushing MR key, turn on POWER (frequency section lights on). Wait there for about 10 seconds (until memory is initialized), then turn off POWER.</p> <p>4) Without specification of SSG, standard modulation is applied (MOD : 1kHz, DEV : ±3kHz, AF output : 0.63V/8Ω).</p>	<p>All LCD lights on (Except M4 type)</p>  <p>All LCD lights on (M4 type)</p> 						
2. Lock voltage	<p>1) V band (VHF) FREQ. : 144.980MHz POWER : LOW Receiving and transmission.</p>	DC V.M	TX-RX (A/4)	CV			Check	2.5~4.8V
	<p>2) U band (UHF) Use band SEL key to select a band. FREQ. : 435.000MHz M,M2,M3,M4,E,E2,E3,E9 FREQ. : 445.000MHz K,P Receiving and transmission.</p>	Power meter	Rear panel	ANT				M,M2,M3,M4,E,E2,E3,E9 3.0~5.5V K,P 4.7~5.9V
	<p>3) Pushing the band SEL key, of UHF band, then set to the V2 (V x V) band by the F key, CONT SEL key. V2 (V x V) band FREQ. : 145.040MHz Receiving. After checked, return to the original state with F key, CONT SEL key.</p>		TX-RX (B/4)	CV				2.3~4.6V
3. BPF	<p>1) V band FREQ. : 145.940MHz E,E3,E9 FREQ. : 147.940MHz K,P,M,M2,M3,M4,E2 Connect speaker to EXT. SP2, operating AF VR of each band. SSG : Lowering SSG from -113dBm (0.5μV), adjust it between -120dBm (0.23μV) to -121dBm (0.2μV).</p>	DC V.M SSG	TX-RX (A/4) Rear panel	SM ANT EXT. SP2	TX-RX (A/4)	L4,5,7 L10	Voltage MAX	Ref. value : approx. 2.5V Except operating AF VR : MIN AF output appear from external speaker.
	<p>2) U band FREQ. : 435.040MHz M,M2,M3,M4,E,E2,E3,E9 FREQ. : 445.040MHz K,P SSG : Lowering SSG from -113dBm (0.5μV), adjust it between -120dBm (0.23μV) to -121dBm (0.2μV).</p>		TX-RX (B/4) Rear panel	SM ANT EXT. SP2	TX-RX (B/4)	L214		

ADJUSTMENT

Receiver Section

Item	Condition	Measurement			Adjustment			Specifications/Remarks
		Test-equipment	Unit	Terminal	Unit	Parts	Method	
1. Sensitivity	1) V band E,E3,E9 FREQ. : 144.040MHz FREQ. : 145.040MHz FREQ. : 145.940MHz K,P,M,M2,M3,M4,E2 FREQ. : 144.040MHz FREQ. : 145.940MHz FREQ. : 147.940MHz SSG : -122dBm (0.18μV)	Distortion meter Oscilloscope AF V.M	Rear panel	EXT. SP			Check	SINAD 12dB or more.
	2) U band M,M2,M3,M4,E,E2,E3,E9 FREQ. : 430.040MHz FREQ. : 435.040MHz FREQ. : 439.940MHz K,P FREQ. : 438.040MHz FREQ. : 445.040MHz FREQ. : 449.940MHz SSG : -122dBm (0.18μV)							SINAD 12dB or more.
	3) Display control unit LED lighting on V2 (V x V) or U2 (U x U) with F key, CONT SEL key. After check, return to the original state with F key, CONT SEL key. Switching the LED lit side with SEL key, set a band for confirmation with F key, CONT SEL key, once again. V2 band FREQ. : 145.040MHz SSG : -118dBm (0.28μV)							SINAD 12dB or more.
	4) U2 band FREQ. : 435.040MHz M,M2,M3,M4,E,E2,E3,E9 FREQ. : 445.040MHz K,P SSG : -118dBm (0.28μV)							SINAD 12dB or more.
2. High level input S/N	1) V band FREQ. : 145.040MHz E,E3,E9 FREQ. : 145.940MHz K,P,M,M2,M3,M4,E2 SSG : -53dBm (500μV) AF output : 2.83V/8Ω	Oscilloscope AF V.M SSG	Rear panel	EXT. SP			Check	S/N 44dB or more.
	2) U band FREQ. : 435.040MHz M,M2,M3,M4,E,E2,E3,E9 FREQ. : 445.040MHz K,P SSG : -53dBm (500μV) AF output : 2.83V/8Ω							S/N 42dB or more.

ADJUSTMENT

Item	Condition	Measurement			Adjustment			Specifications/Remarks		
		Test-equipment	Unit	Terminal	Unit	Parts	Method			
3. Distortion	1) V band FREQ. : 145.040MHz E,E3,E9 FREQ. : 145.940MHz K,P,M,M2,M3,M4,E2 SSG : -73dBm (50μV) AF output : 4V/8Ω	Distortion meter Oscilloscope AF V.M SSG	Rear panel	EXT. SP			Check	5% or less.		
	2) U band FREQ. : 435.040MHz M,M2,M3,M4,E,E2,E3,E9 FREQ. : 445.040MHz K,P SSG : -73dBm (50μV) AF output : 4V/8Ω							5% or less.		
4. S-meter	1) V band FREQ. : 145.040MHz E,E3,E9 FREQ. : 145.940MHz K,P,M,M2,M3,M4,E2 SSG : -96dBm (3.5μV)	SSG	Rear panel	ANT	TX-RX (A/4)	VR1	Set the SSG output to the point where the S-meter puts out lights by 1 dots from full lighting.			
	2) U band FREQ. : 435.040MHz M,M2,M3,M4,E,E2,E3,E9 FREQ. : 445.040MHz K,P SSG : -96dBm (3.5μV)									VR201
	3) V,U band FREQ. : In the above SSG : -94dBm (4.5μV)								Check	S-meter full lighting.
	4) SSG : OFF									S-meter lights out.
5. Squelch	1) V band FREQ. : 145.040MHz E,E3,E9 FREQ. : 145.940MHz K,P,M,M2,M3,M4,E2 SSG : OFF Turning the squelch knob, set it to a point where noise disappears.	Oscilloscope SSG	Rear panel	EXT. SP			Check	Squelch knob position 8 : 00 ~ 11 : 00 BUSY lights off.		
	2) SSG : -127dBm (0.1μV)							Squelch open. BUSY lights on.		
	3) SQL knob : Clockwise MAX							AF output disappear. BUSY lights off.		
	4) SSG : -110dBm (0.7μV)							Squelch open. Note : If not squelch opened, minimum 20dB NQ level is acceptable.		
	5) U band FREQ. : 435.040MHz M,M2,M3,M4,E,E2,E3,E9 FREQ. : 445.040MHz K,P SSG : OFF Turning the squelch knob, set it to a point where noise disappears.							Check	Squelch knob position 8 : 00 ~ 11 : 00 BUSY lights off.	
	6) SSG : -127dBm (0.1μV)							Squelch open. BUSY lights on.		
	7) SQL knob : Clockwise MAX							AF output disappear. BUSY lights off.		
	8) SSG : -110dBm (0.7μV)							Squelch open. Note : If not squelch opened, minimum 20dB NQ level is acceptable.		

ADJUSTMENT

Transmission Section

Item	Condition	Measurement			Adjustment			Specifications/Remarks
		Test-equipment	Unit	Terminal	Unit	Parts	Method	
1. Transmission frequency	1) U band FREQ. : 435.000MHz M,M2,M3,M4,E,E2,E3,E9 FREQ. : 445.000MHz K,P	f. counter Dummy	Rear panel	ANT	TX-RX (A/4)	TC1	435.000MHz M,M2, M3,M4,E,E2,E3,E9 445.000MHz K,P	Not warm up the set. (f + 1000Hz) ± 100Hz
2-1. POWER VHF band	1) FREQ. : 144.980MHz E,E3,E9 FREQ. : 145.980MHz K,P,M,M2,M3,M4,E2 Transmission.	Power meter Ammeter	Rear panel	ANT	TX-RX (A/4)	VR3, 4	Clockwise MAX	57W or more.
	2) POWER : HI Transmission.					VR3	53W	±1W 11.5A or less.
	3) POWER : MID Transmission.					VR4	12W	±1W
	4) POWER : LOW Transmission.						Check	3.0~8.0W
	5) E,E3,E9 FREQ. : 144.000MHz FREQ. : 145.980MHz K,P,M,M2,M3,M4,E2 FREQ. : 144.000MHz FREQ. : 147.980MHz POWER : HI Transmission							46~59W 11.5A or less.
	6) POWER : MID Transmission.							10~14W
	7) POWER : LOW Transmission.							3.0~8.0W
	8) POWER : HI M2,M3,E2 Transmission.							Power appear.
2-2. POWER UHF band	1) U band FREQ. : 435.000MHz M,M2,M3,M4,E,E2,E3,E9 FREQ. : 445.000MHz K,P Transmission.				TX-RX (B/4)	VR203 VR204	Clockwise MAX	35W or more.
	2) POWER : HI Transmission.					VR203	34W	±1W
	3) POWER : MID Transmission.					VR204	12W	±1W
	4) POWER : LOW Transmission.						Check	3.0~8.0W
	5) M,M2,M3,M4,E,E2,E3,E9 FREQ. : 430.000MHz FREQ. : 439.980MHz K,P FREQ. : 449.980MHz FREQ. : 438.080MHz POWER : HI Transmission.							28~42W 10A or less.
	6) POWER : MID Transmission.							10~14W
	7) POWER : LOW Transmission.							3.0~8.0W

ADJUSTMENT

Item	Condition	Measurement			Adjustment			Specifications/Remarks
		Test-equipment	Unit	Terminal	Unit	Parts	Method	
3. DEV	1) V band FREQ. : 144.980MHz E,E3,E9 FREQ. : 145.980MHz K,P,M,M2,M3,M4,E2 AG : 1kHz/25mV E,E2,E3,E9 AG : 1kHz/50mV K,P,M,M2,M3,M4 Transmission	Linear detector Oscilloscope AG	Rear panel	ANT	TX-RX (A/4)	VR2	±4.3kHz (+, - with a larger value)	±100Hz
						Check	±3.0kHz +0.9kHz -0.4kHz	
	TX-RX (B/4)				VR202	±4.3kHz (+, - with a larger value)	±100Hz	
						Check	±3.0kHz +0.9kHz -0.4kHz	
4. TONE	1) V band TONE key : ON Transmission. After checked TONE key : OFF	Linear detector Oscilloscope	Rear panel	ANT			Check	±0.5~1.5kHz
	2) U band TONE key : ON Transmission. After checked TONE key : OFF							±0.5~1.5kHz
5. Protection	1) V band FREQ. : 145.980MHz E,E3,E9 FREQ. : 147.980MHz K,P,M,M2,M3,M4,E2 ANT : OPEN Transmission.	Ammeter					Check	12.0A or less.
	2) U band FREQ. : 439.980MHz M,M2,M3,M4,E,E2,E3,E9 FREQ. : 449.980MHz K,P ANT : OPEN Transmission.							

ADJUSTMENT

Adjustment Points

•TX-RX UNIT (A/4)
Upper side

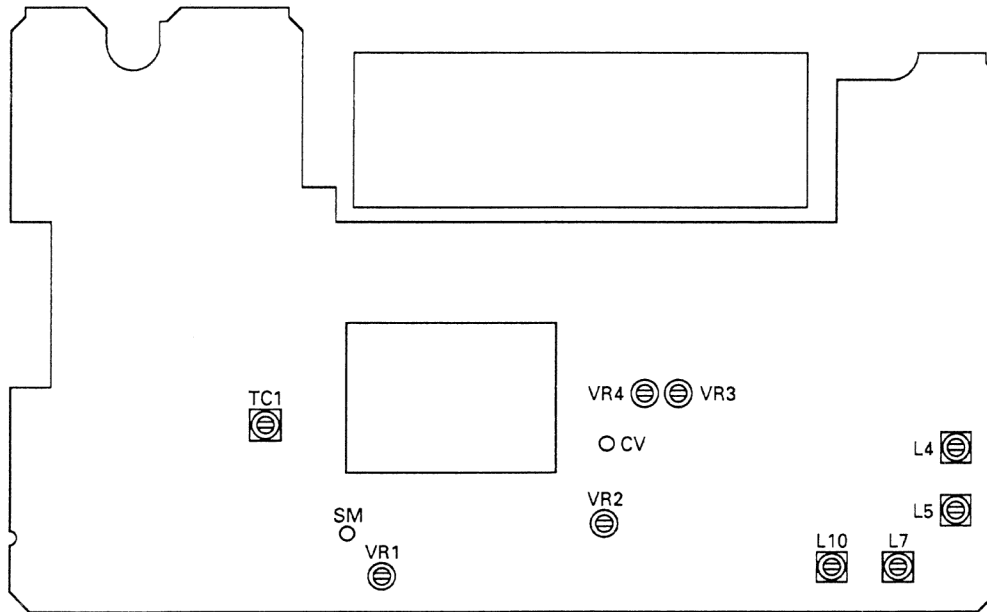

UHF TC1 : Transmission frequency
 L4, L5, L7, L10 : BPF
 VHF VR1 : S-meter
 VR2 : DEV
 VR3 : POWER (HI)
 VR4 : POWER (MD)

•TX-RX UNIT (B/4)
Lower side

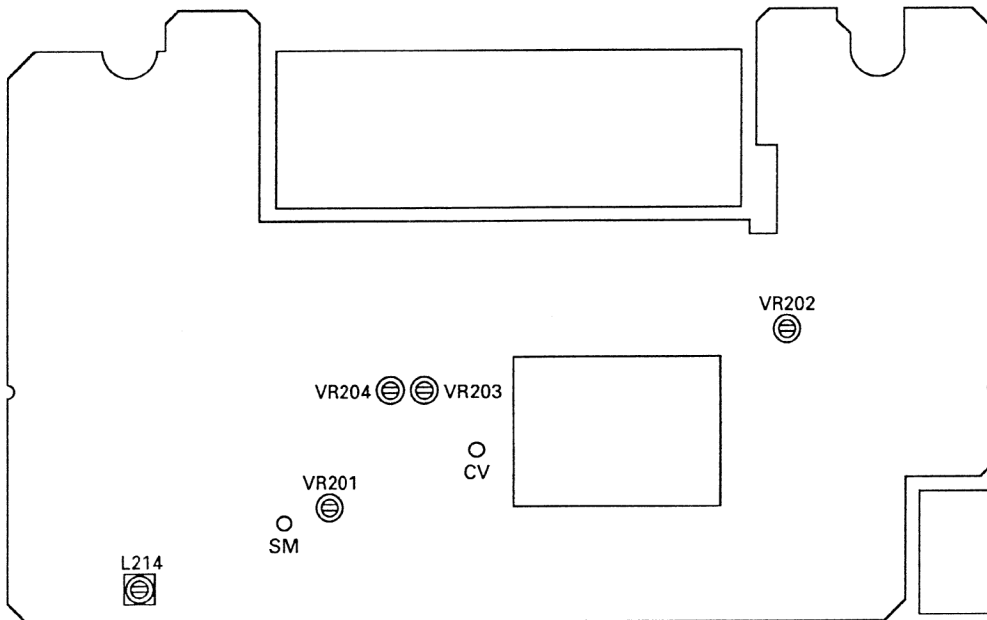

UHF L214 : BPF
 VR201 : S-meter
 VR202 : DEV
 VR203 : POWER (HI)
 VR204 : POWER (MID)

TM-733A/E PC BOARD VIEWS

TX-RX UNIT (X57-436X-XX) (A/4) Component side view 0-11 : K,P 0-21 : M 0-22 : M2,M3 0-23 : M4 2-71 : E,E3,E9 2-72 : E2

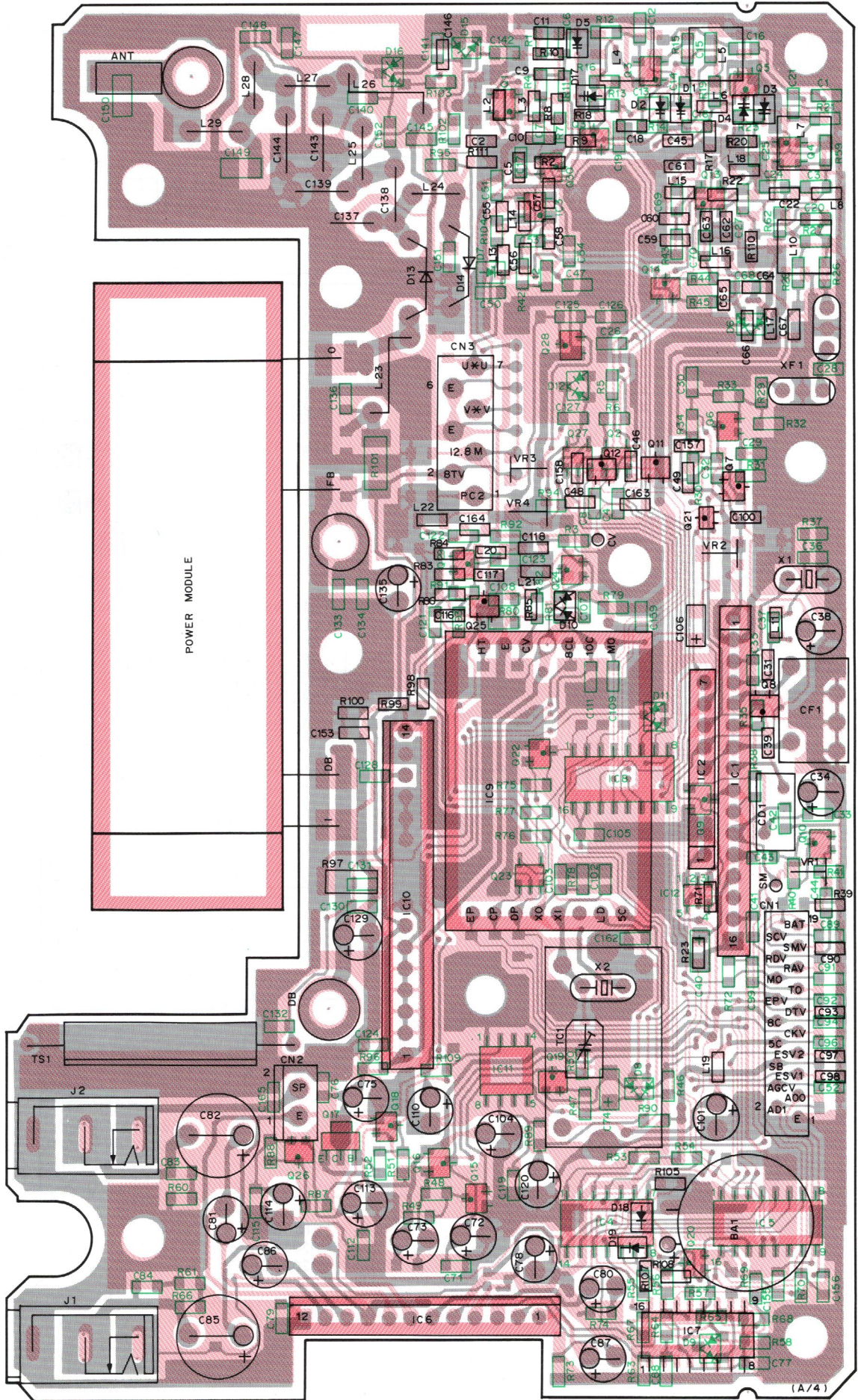

(A/4)

TX-RX UNIT (X57-436X-XX) (A/4) Foil side view 0-11 : K,P 0-21 : M 0-22 : M2,M3 0-23 : M4 2-71 : E,E3,E9 2-72 : E2

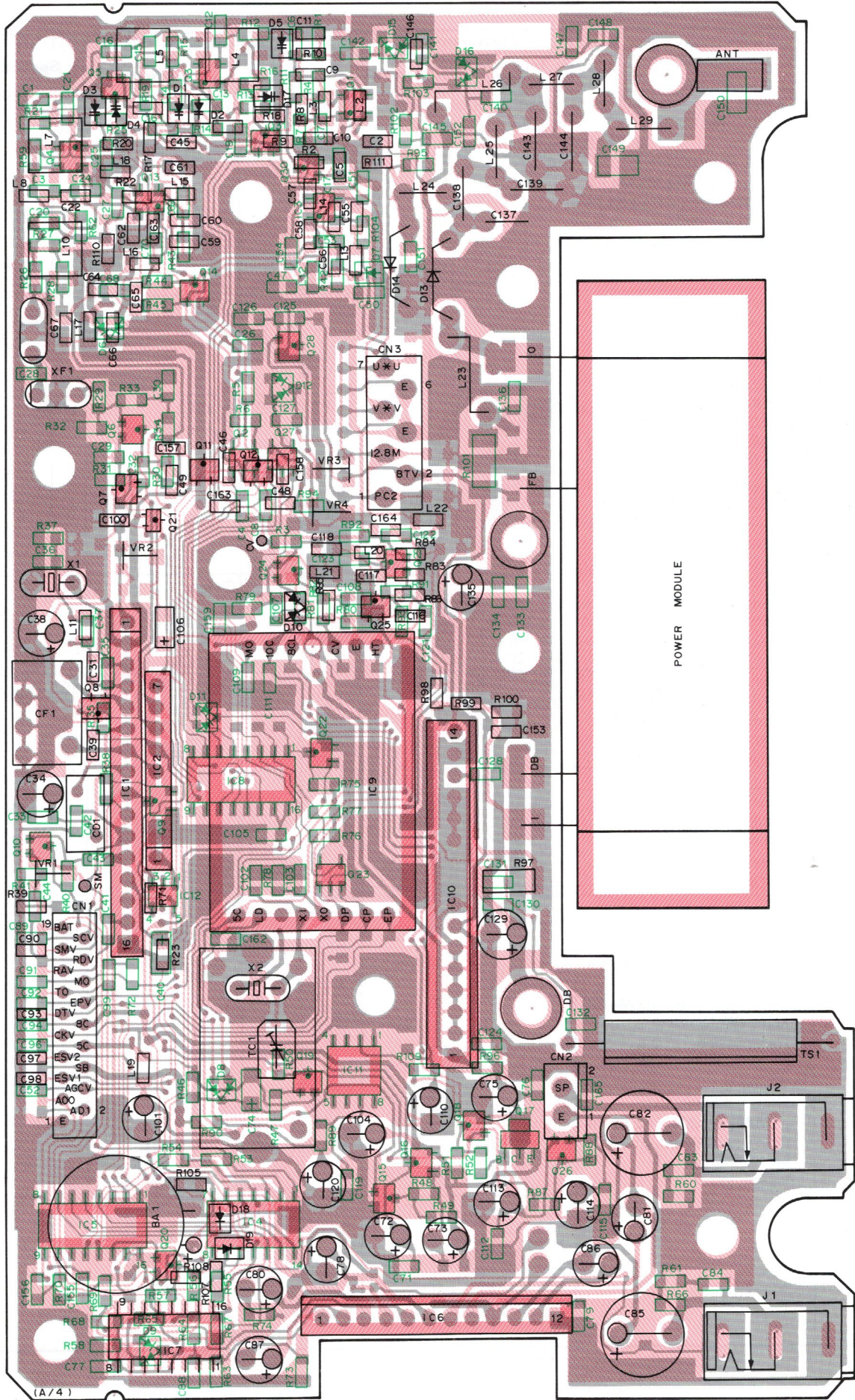

TX-RX UNIT/144MHZ (X57-436X-XX) (A74)

0-11 : TM-733A (K,P)
0-21 : TM-733A (M)
0-22 : TM-733A (M2,M3)

0-23 : TM-733A (M4)
2-71 : TM-733E (E,E3,E9)
2-72 : TM-733E (E2)

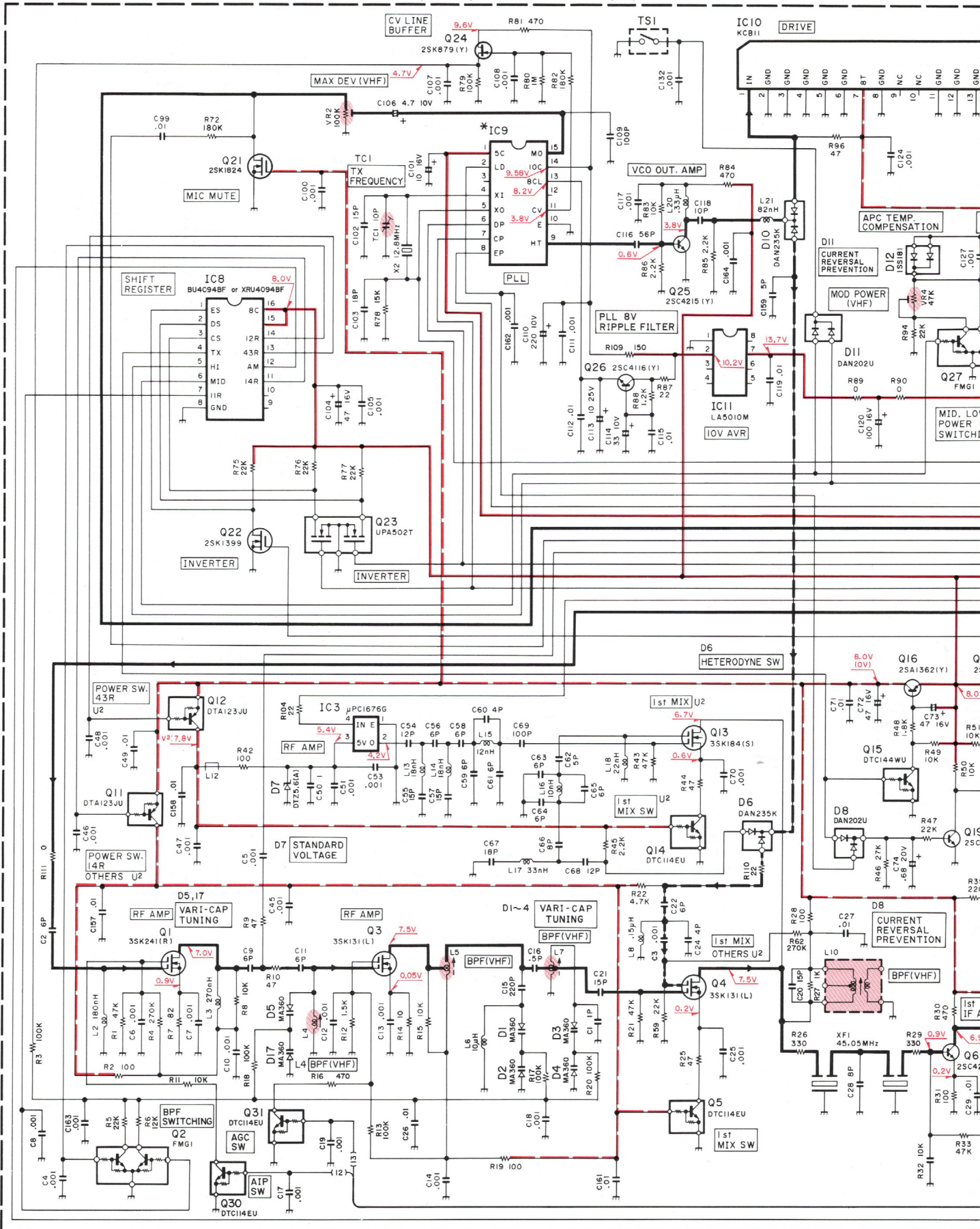

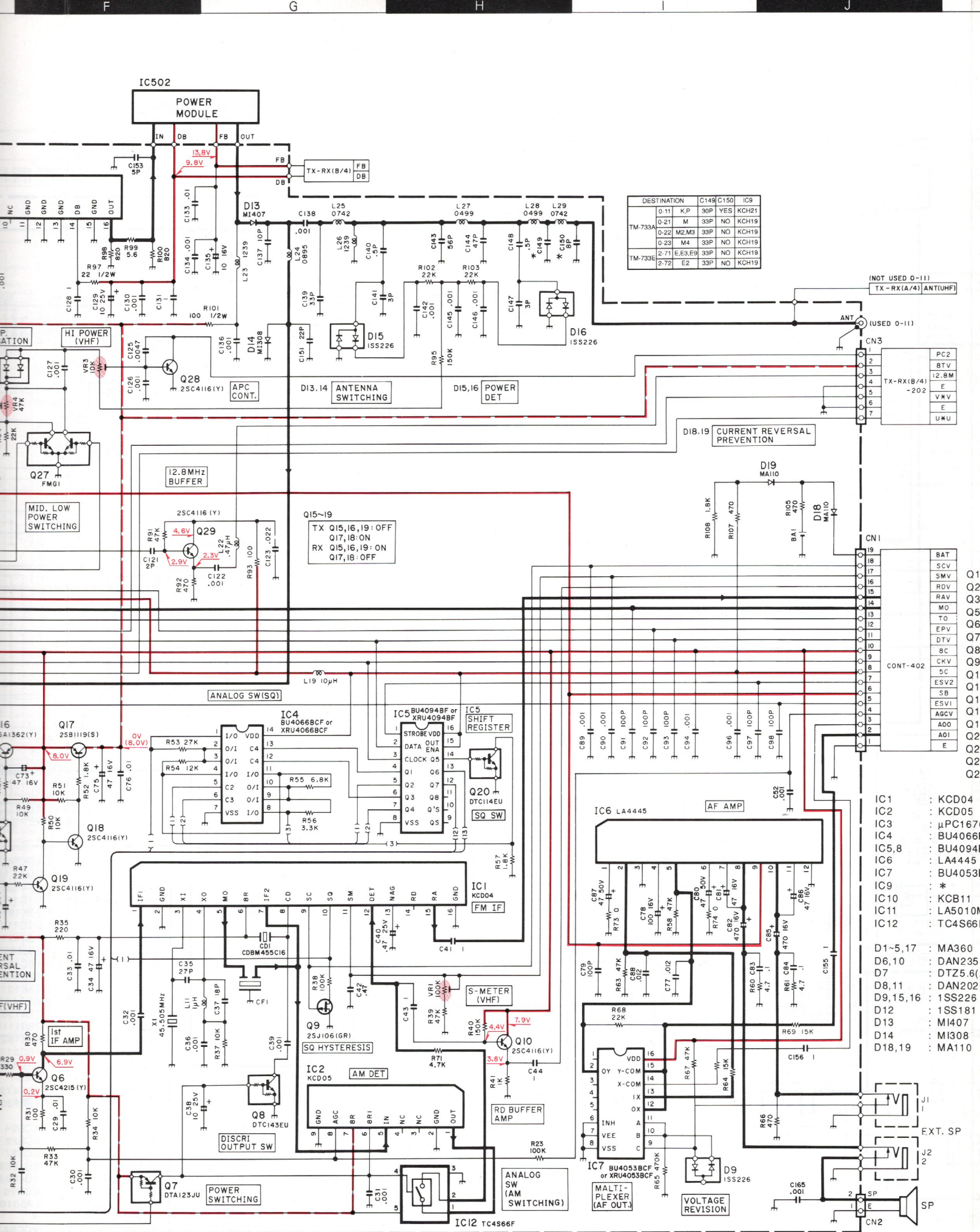

	DESTINATION	C149	C150	IC9	
TM-733A	0-11	K,P	30P	YES	KCH21
	0-21	M	33P	NO	KCH19
	0-22	M2,M3	33P	NO	KCH19
TM-733B	0-23	M4	33P	NO	KCH19
	2-71	E,E3,E9	33P	NO	KCH19
TM-733C	2-72	E2	33P	NO	KCH19

(NOT USED 0-11)
TX-RX(A/4) ANT(UHF)

(USED 0-11)
ANT
CN3
1
2
3
4
5
6
7

BAT
SCV
SMV
BTV
RDV
RAV
MO
TO
EPV
DTV
8C
CKV
5C
ESV2
5B
ESV1
AGCV
A00
A01
E

IC1 : KCD04
IC2 : KCD05
IC3 : μPC1677
IC4 : BU4066B
IC5,8 : BU4094B
IC6 : LA4445
IC7 : BU4053B
IC9 : *
IC10 : KCB11
IC11 : LA5010M
IC12 : TC4S66F

D1-5,17 : MA360
D6,10 : DAN235
D7 : DTZ5.6
D8,11 : DAN202
D9,15,16 : 1SS226
D12 : 1SS181
D13 : MI407
D14 : MI308
D18,19 : MA110

CIRCUIT DIAGRAM TM-733A/E

2SA1362
2SC4215
DTC114EU
DTC144WU



2SC4116
DTA123JU
DTC143EU

LA5010M

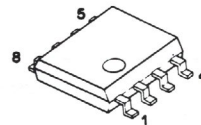

2SJ106
2SK879



LA4445

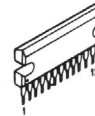

3SK131
3SK184
3SK241



μPC1676G

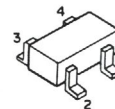

2SB1119



TC4S66F

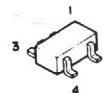

FMG1



2SK1399
2SK1824

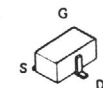

XRU4053BCF
XRU4094BF

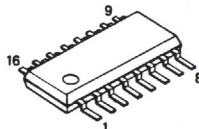

μPA502T

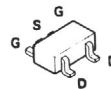

XRU4066BCF

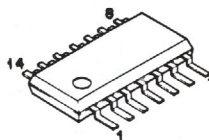

USED 0-11)
-RX(A/4) ANT(UHF)

D 0-11)

PC2
BTV
12.8M
E
VXV
E
UXU

X-RX(B/4)
-202

BAT
SCV
SMV
RDV
RAV
MO
TO
EPV
DTV
8C
CKV
5C
ESV2
Q13
SB
ESV1
AGCV
A00
A01
E

CONT-402

- Q1 : 3SK241(R)
- Q2,27 : FMG1
- Q3,4 : 3SK131(L)
- Q5,14,20,30,31 : DTC114EU
- Q6,25 : 2SC4215(Y)
- Q7,11,12 : DTA123JU
- Q8 : DTC143EU
- Q9 : 2SJ106(GR)
- Q10,18,19,26,28,29 : 2SC4116(Y)
- Q13 : 3SK184(S)
- Q15 : DTC144WU
- Q16 : 2SA1362(Y)
- Q17 : 2SB1119(S)
- Q21 : 2SK1824
- Q22 : 2SK1399
- Q23 : UPA502T
- Q24 : 2SK879(Y)

- 1 : KCD04
- 2 : KCD05
- 3 : μPC1676G
- 4 : BU4066BCF or XRU4066BCF
- 5,8 : BU4094BF or XRU4094BF
- 6 : LA4445
- 7 : BU4053BCF or XRU4053BCF
- 9 : *
- 10 : KCB11
- 11 : LA5010M
- 12 : TC4S66F

- ~5,17 : MA360
- 1,10 : DAN235K
- DTZ5.6(A)
- 1,11 : DAN202U
- 1,15,16 : 1SS226
- 2 : 1SS181
- 3 : MI407
- 4 : MI308
- 8,19 : MA110

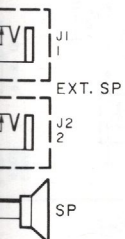

TM-733A/E CIRCUIT DIAGRAM

- 0-11 : TM-733A (K,P)
- 0-21 : TM-733A (M)
- 0-22 : TM-733A (M2,M3)
- 0-23 : TM-733A (M4)
- 2-71 : TM-733E (E,E3,E9)
- 2-72 : TM-733E (E2)

TX-RX UNIT/430MHz (X57-436X-XX)(B/4)

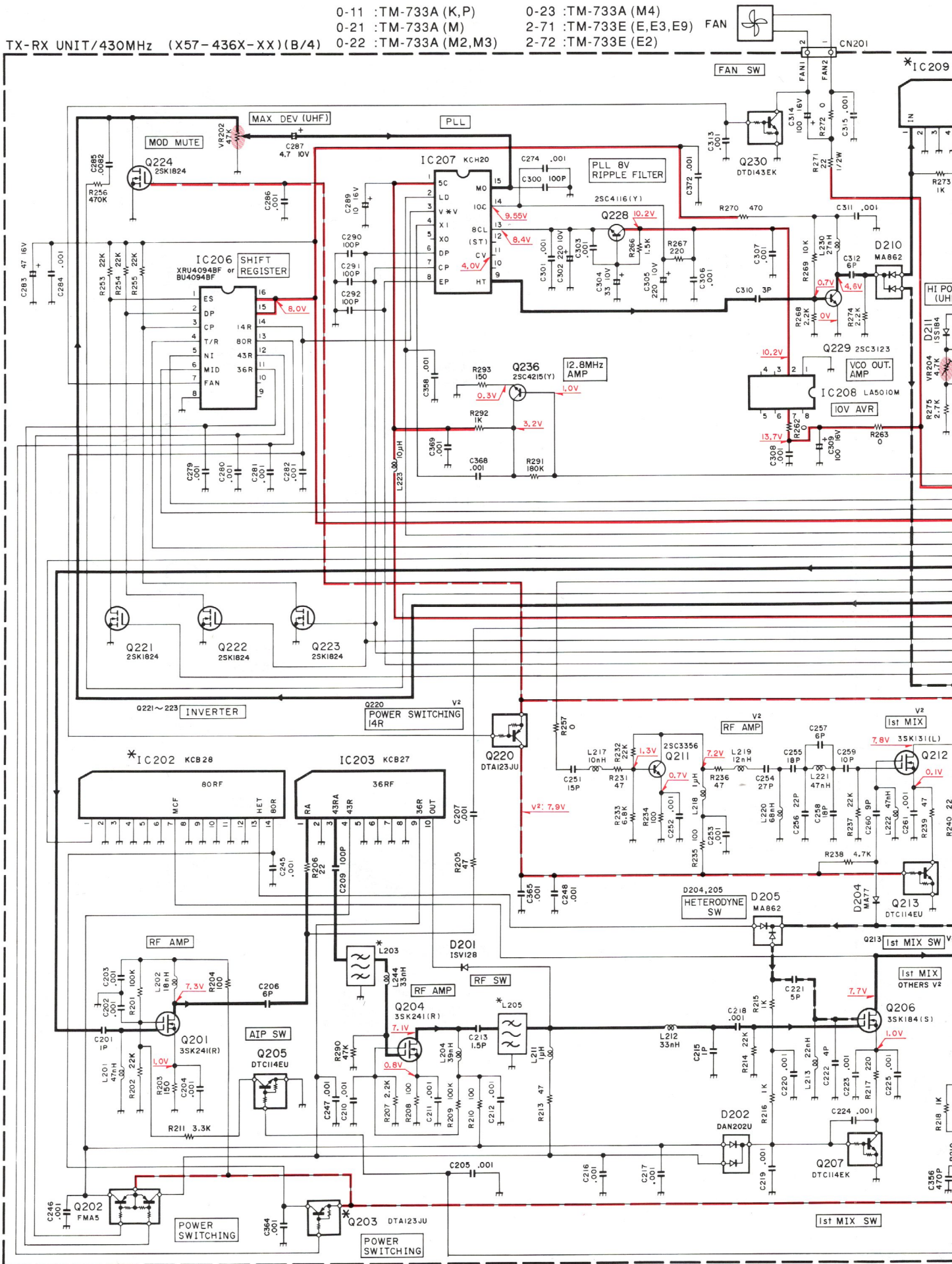

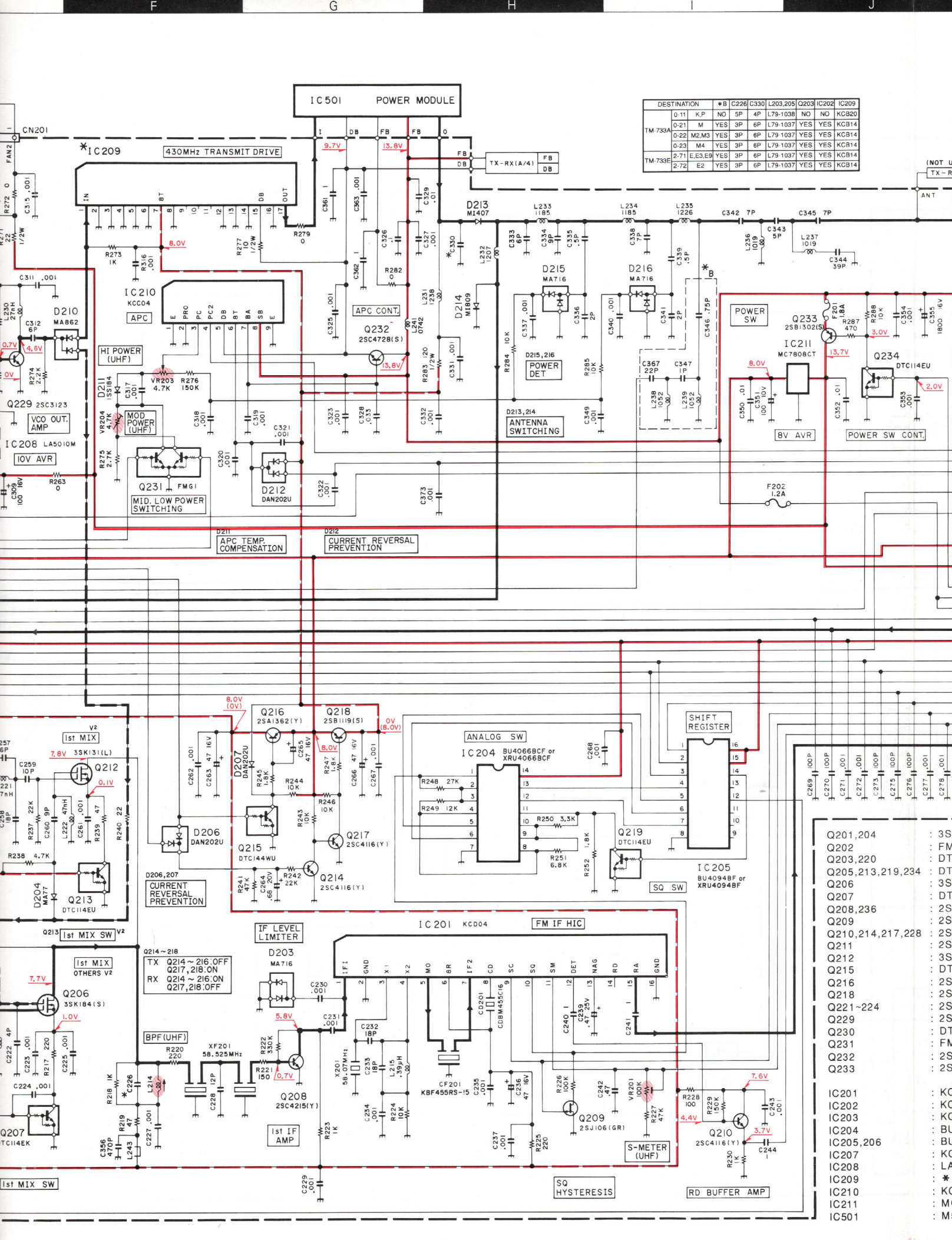

	DESTINATION	#B	C226	C330	L203,205	Q203	IC202	IC209
TM-733A	0-11	KP	NO	5P	4P	L79-1038	NO	KC820
	0-21	M	YES	3P	6P	L79-1037	YES	KCB14
	0-22	M2,M3	YES	3P	6P	L79-1037	YES	KCB14
TM-733E	0-21	M4	YES	3P	6P	L79-1037	YES	KCB14
	2-71	E,E3,E9	YES	3P	6P	L79-1037	YES	KCB14
	2-72	E2	YES	3P	6P	L79-1037	YES	KCB14

- Q201,204 : 3S
- Q202 : FM
- Q203,220 : DT
- Q205,213,219,234 : DT
- Q206 : 3S
- Q207 : DT
- Q208,236 : 2S
- Q209 : 2S
- Q210,214,217,228 : 2S
- Q211 : 2S
- Q212 : 3S
- Q215 : DT
- Q216 : 2S
- Q218 : 2S
- Q221~224 : 2S
- Q229 : 2S
- Q230 : DT
- Q231 : FM
- Q232 : 2S
- Q233 : 2S
- IC201 : KC
- IC202 : KC
- IC203 : KC
- IC204 : BU
- IC205,206 : BU
- IC207 : KC
- IC208 : *
- IC209 : LA
- IC210 : KC
- IC211 : M
- IC501 : M

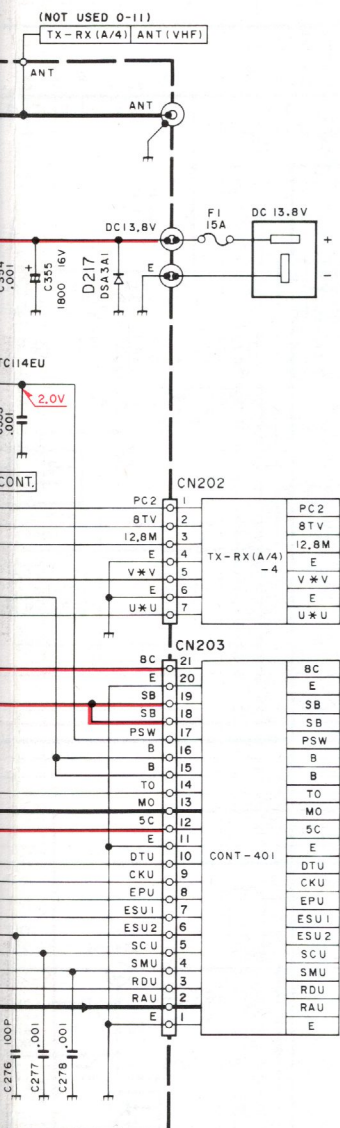

- 2SA1362
- 2SC3356
- 2SC4215
- DTC114EK
- DTC144WU
- 2SC3123
- 2SC4116
- DTA123JU
- DTC114EU
- DTD143EK



2SJ106



3SK131
3SK184
3SK241

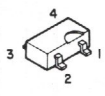

2SB1119
2SB1302

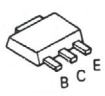

FMA5
FMG1

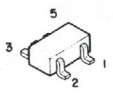

LA5010M

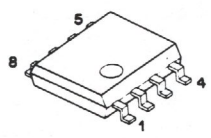

MC7808CT

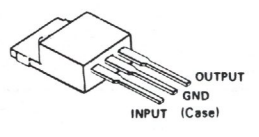

XRU4094BF

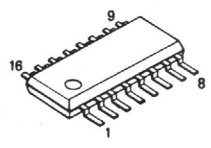

XRU4066BCF

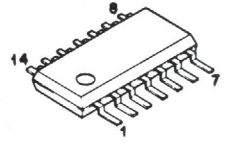

2SK1824

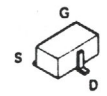

2SC4728

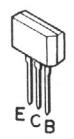

- : 3SK241(R)
- : FMA5
- : DTA123JU
- 234 : DTC114EU
- : 3SK184(S)
- : DTC114EK
- : 2SC4215(Y)
- : 2SJ106(GR)
- 228 : 2SC4116(Y)
- : 2SC3356
- : 3SK131(L)
- : DTC144WU
- : 2SA1362(Y)
- : 2SB1119(S)
- : 2SK1824
- : 2SC3123
- : DTD143EK
- : FMG1
- : 2SC4728(S)
- : 2SB1302(S)
- : KCD04
- : KCB28
- : KCB27
- : BU4066BCF or XRU4066BCF
- : BU4094BF or XRU4094BF
- : KCH20
- : LA5010M
- : *
- : KCC04
- : MC7808CT
- : M57788MR
- D201 : 1SV128
- D202,206,207,212 : DAN202U
- D203,215,216 : MA716
- D204 : MA77
- D205,210 : MA862
- D211 : 1SS184
- D213 : MI407
- D214 : MI809
- D217 : DSA3A1

TX-RX UNIT (X57-436X-XX) (B/4,D/4) Component side view 0-11 : K,P 0-21 : M 0-22 : M2,M3 0-23 : M4 2-71 : E,E3,E9 2-72 : E2

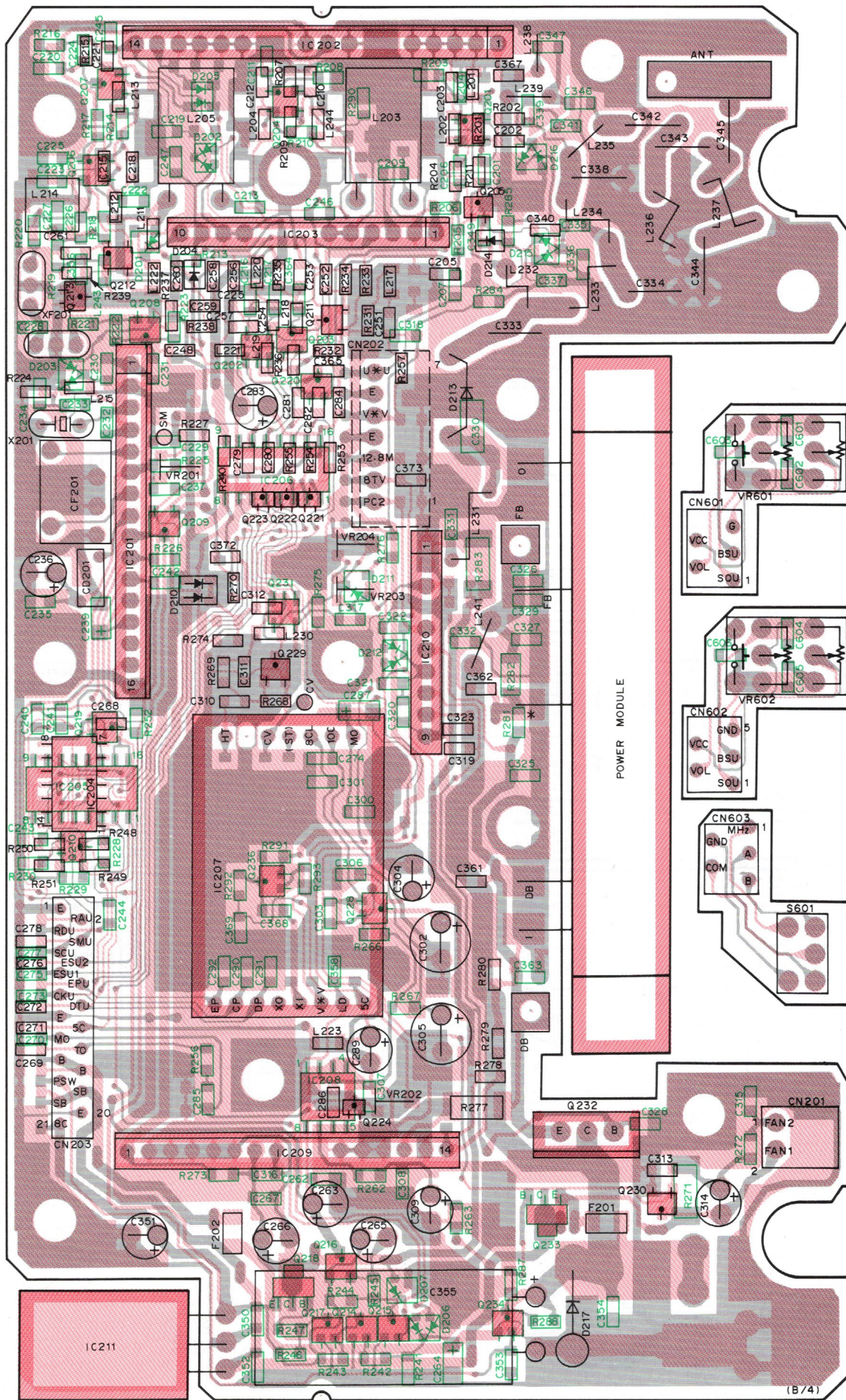

(B/4)

PC BOARD VIEWS TM-733A/E

TX-RX UNIT (X57-436X-XX) (B/4,D/4) Foil side view 0-11 : K,P 0-21 : M 0-22 : M2,M3 0-23 : M4 2-71 : E,E3,E9 2-72 : E2

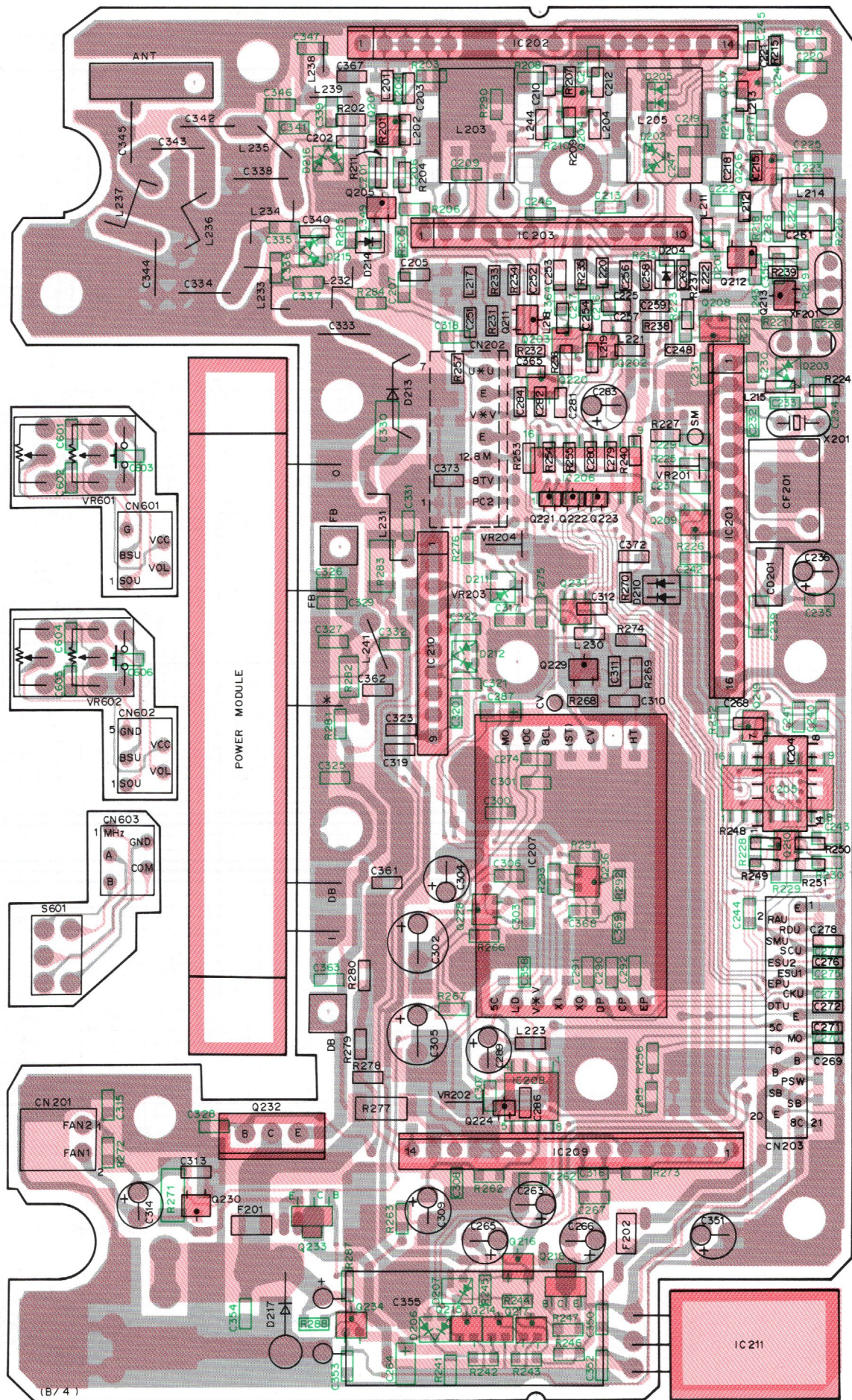

1
2
3
4
5
6
7

TM-733A/E CIRCUIT DIAGRAM

0-11 : TM-733A (K,P) 0-23 : TM-733A (M4)
 0-21 : TM-733A (M) 2-71 : TM-733E (E, E3, E9)
 0-22 : TM-733A (M2, M3) 2-72 : TM-733E (E2)

TX-RX UNIT/CONTROL (X57-436X-XX)(C/4)

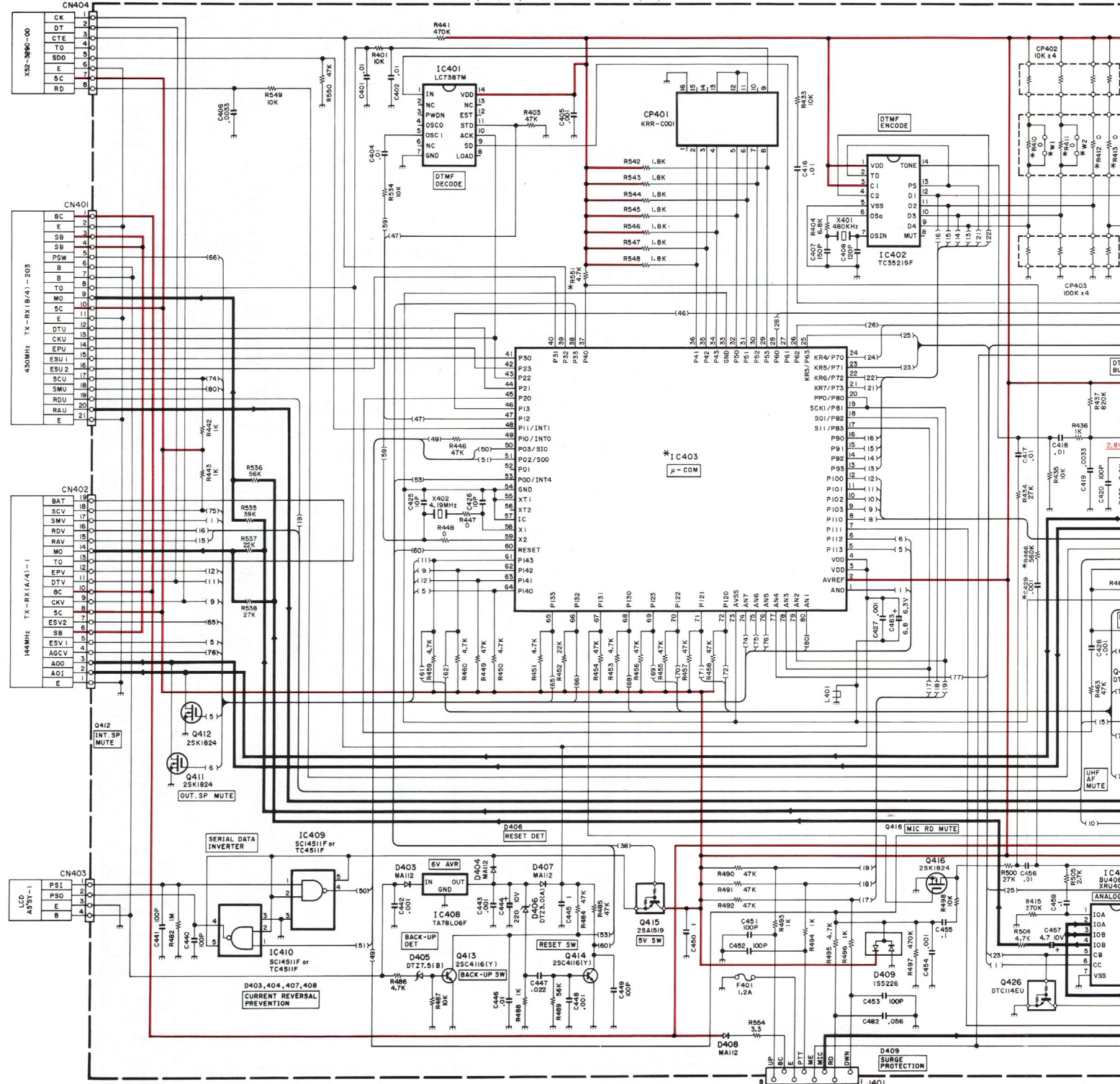

2SA1519
 2SC4116
 DTA123JU
 DTC114EU
 DTC144EU

NJM4558E

TC35219F

LC7387M
 XRU4066BCF

XRU4053BCF

MB87032PF

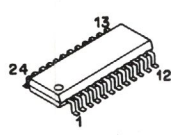
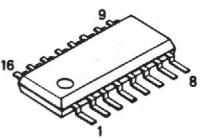
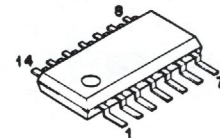
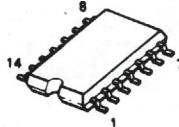
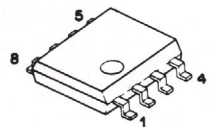

F G H I J

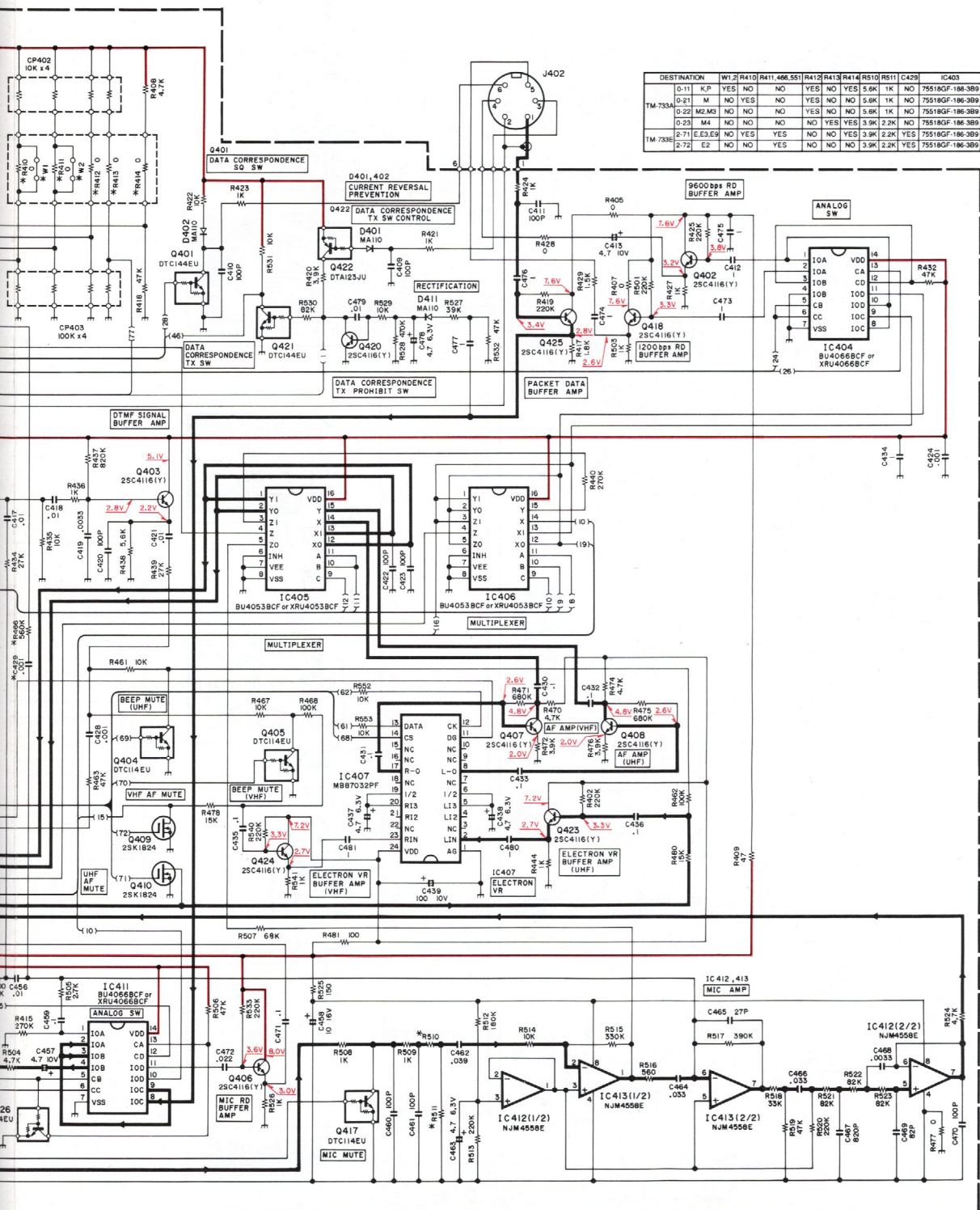

	DESTINATION	W1	W2	R410	R411, 466, 551	R412	R413	R414	R510	R511	C439	IC403
TM-733A	0-21	KP	YES	NO	NO	YES	NO	YES	3.9K	1K	NO	75518GF-186-389
	0-22	M2M3	NO	NO	NO	YES	NO	NO	5.8K	1K	NO	75518GF-186-389
	0-23	M4	NO	NO	NO	NO	YES	YES	3.9K	2.2K	NO	75518GF-186-389
TM-733B	2-71	E3,E9	NO	YES	YES	NO	NO	YES	3.9K	2.2K	YES	75518GF-186-389
	2-72	E2	NO	NO	YES	NO	NO	NO	3.9K	2.2K	YES	75518GF-186-389

- D401,402,411 : MA110
- D403,404,407,408 : MA112
- D405 : DTZ.5(B)
- D406 : DTZ3.0(A)
- D409 : 1SS226

- Q401,421 : DTC144EU
- Q402,403,406~408,413,414,418,420,423~425 : 2SC4116(Y)
- Q404,405,417,426 : DTC114EU
- Q409~412,416 : 2SK1824
- Q415 : 2SA1519
- Q422 : DTA123JU

- IC401 : LC7387M
- IC402 : TC35219F
- IC403 : *
- IC404,411 : BU4066BCF or XRU4066BCF
- IC405,406 : BU4053BCF or XRU4053BCF
- IC407 : MB87032PF
- IC408 : TA78L06F
- IC409,410 : SC14S11F or TC4S11F
- IC412,413 : NJM4558E

TM-733 A/E

2PF

TA78L06F

75518GF-18X-3B9

SC14S11F

2SK1824

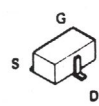
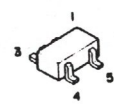
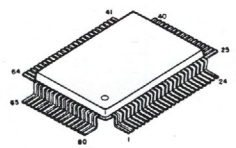
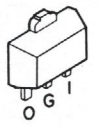
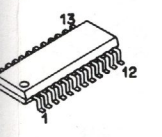

TX-RX UNIT (X57-436X-XX) (C/4)

Component side view

0-11: K,P 0-21: M 0-22: M2,M3 0-23: M4 2-71: E,E3,E9 2-72: E2

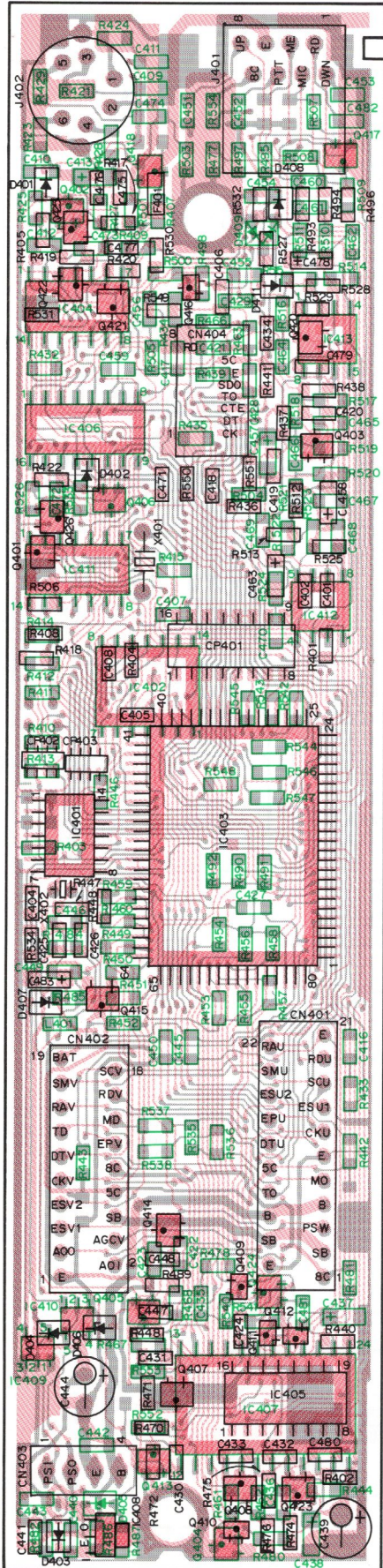

TX-RX UNIT (X57-436X-XX) (C/4)

Foil side view

0-11: K,P 0-21: M 0-22: M2,M3 0-23: M4 2-71: E,E3,E9 2-72: E2

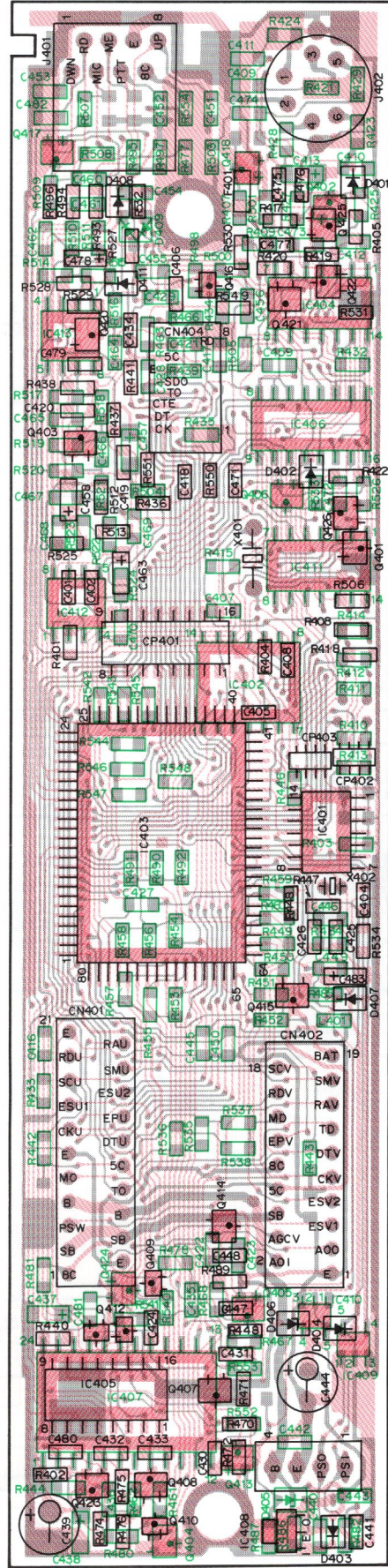

PC BOARD VIEWS TM-733A/E

LCD ASSY (B38-070X-25) 8 : M4 9 : K, P, M, M2, M3, E, E2, E3, E9

Component side view

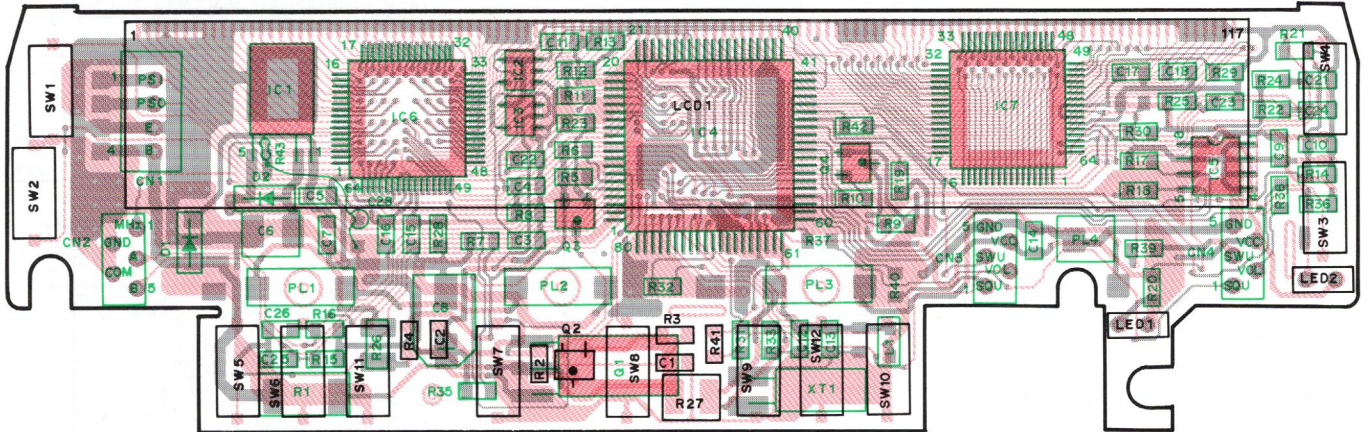

LCD ASSY (B38-070X-25) 8 : M4 9 : K, P, M, M2, M3, E, E2, E3, E9

LCD ASSY TEMPORARY UNIT

Foil side view

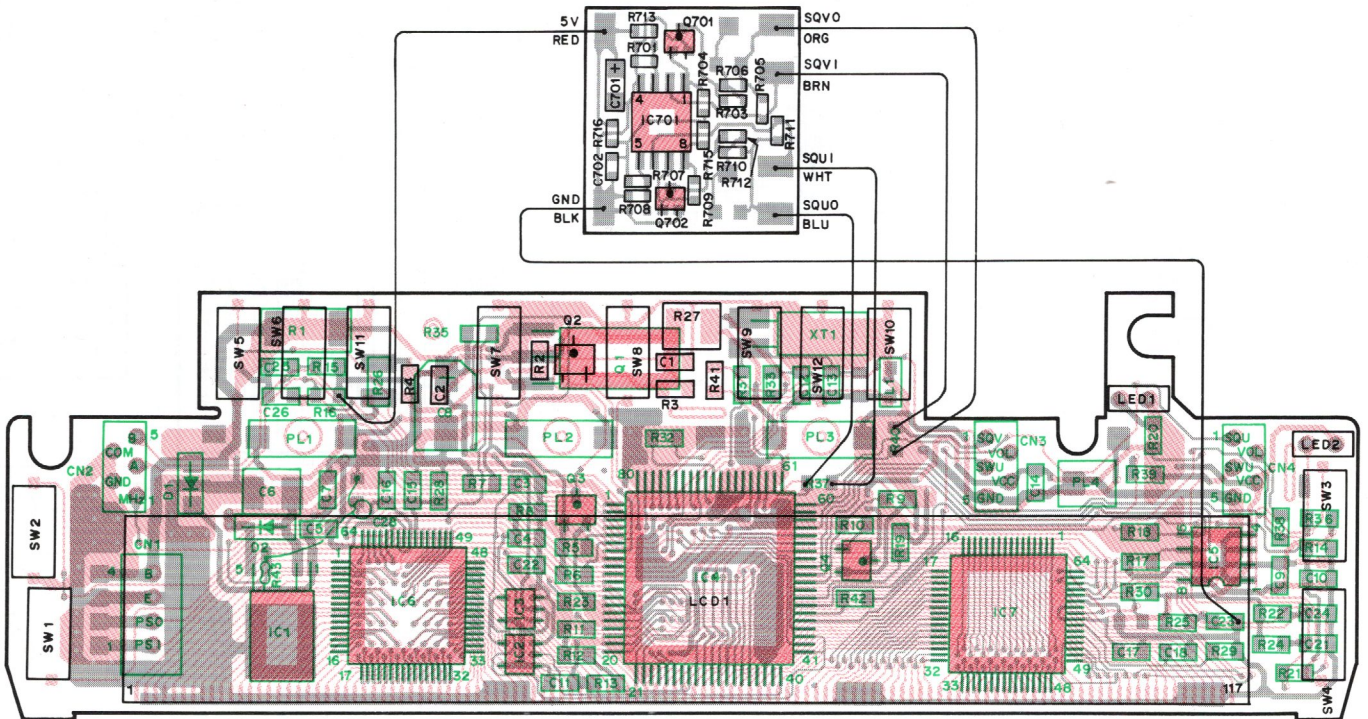

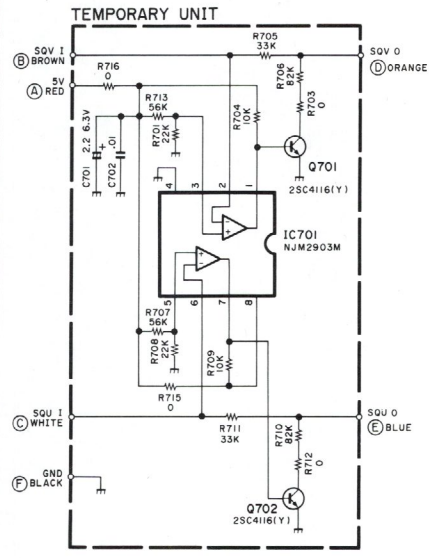
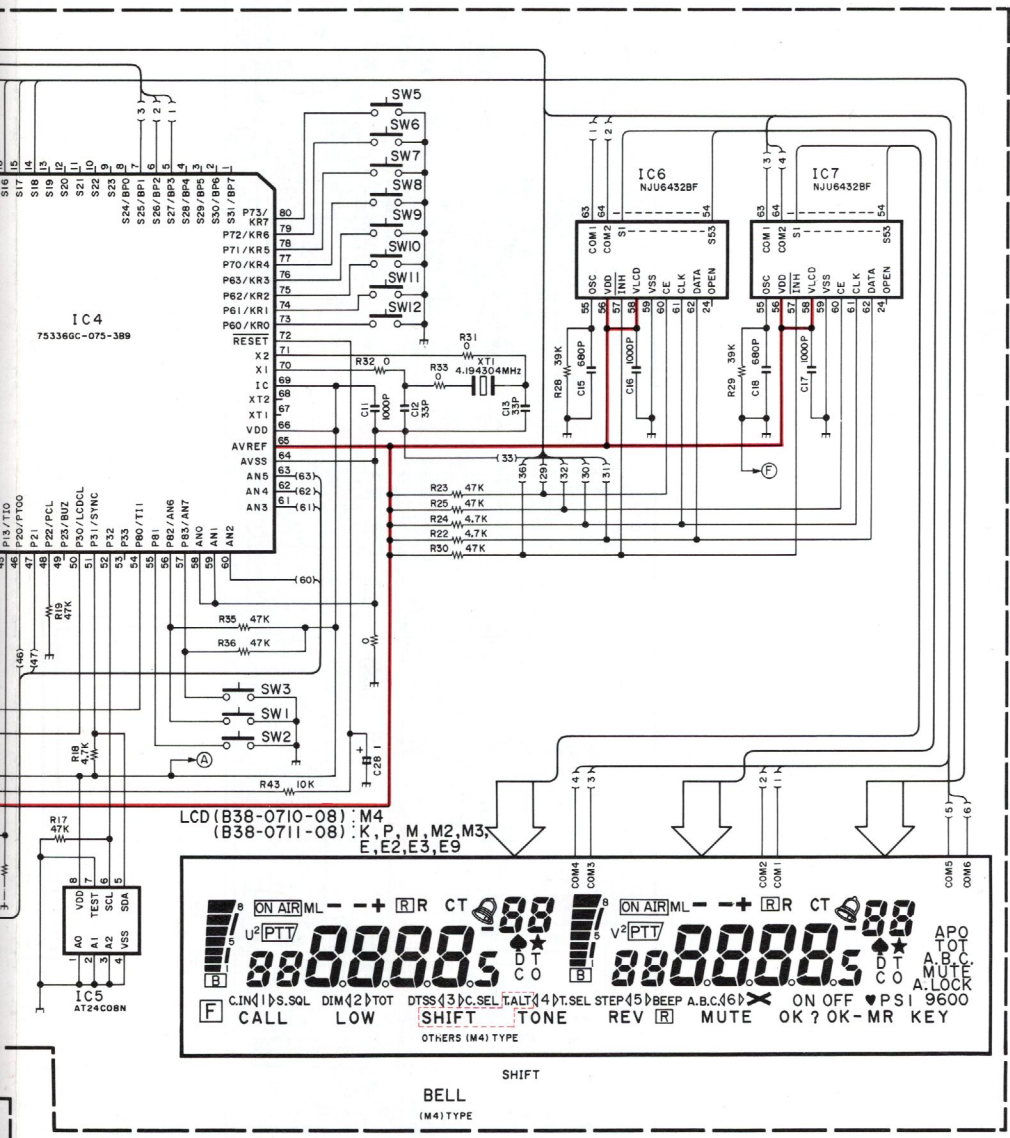

- IC1 : L78LR05B-FA
- IC2,3 : SC14S11F or TC4S11F
- IC4 : 75336GC-075-3B9
- IC5 : AT24C08N
- IC6,7 : NJU6432BF
- Q1 : 2SB1149(M)
- Q2 : 2SC2712(Y)
- Q3,4 : 2SA1162(Y)
- D1 : LFB-01
- D2 : MA110
- LED1,2 : MBG3373K

TM-733A/E

BLOCK D

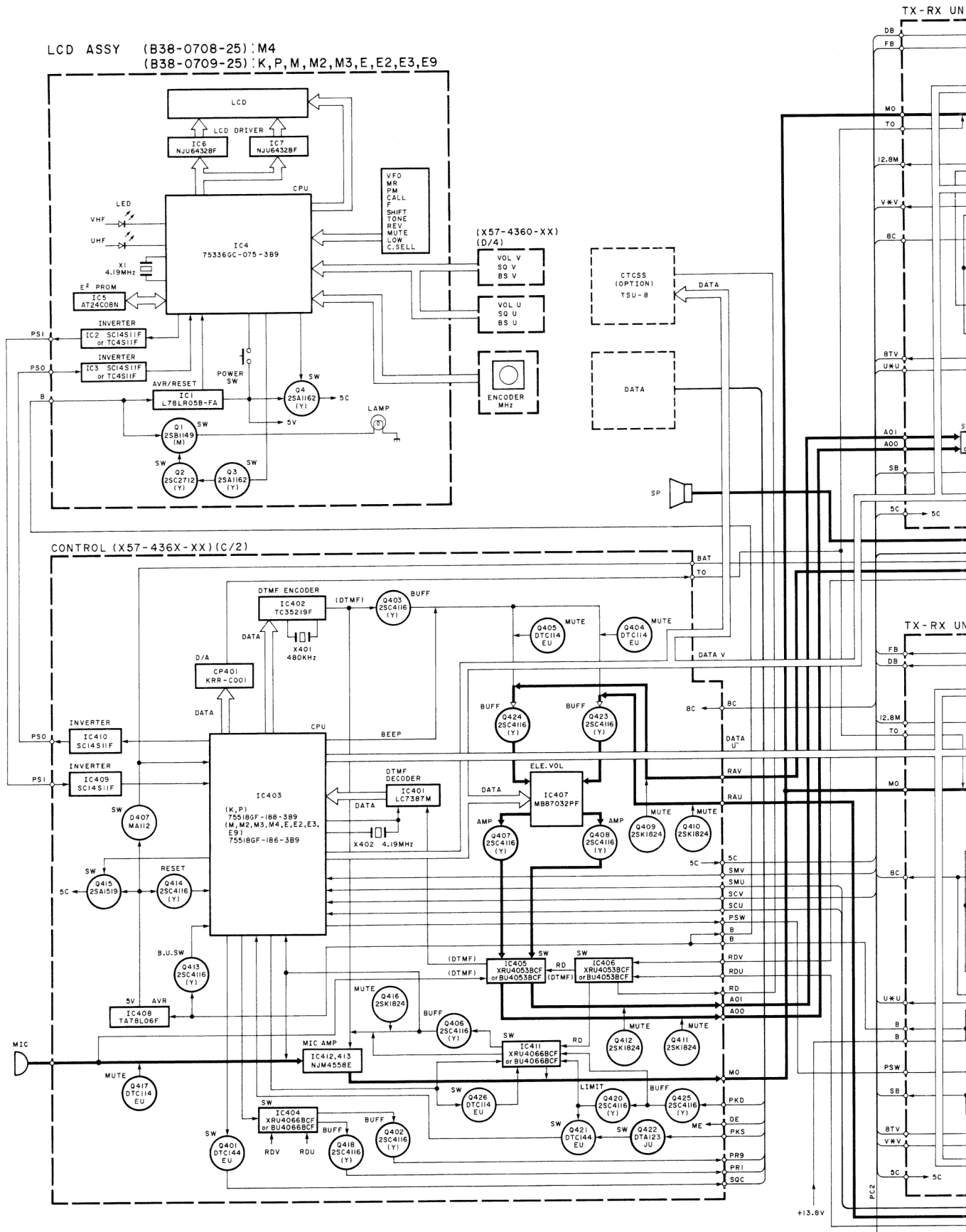

A/E TM-733A/E

BLOCK DIAGRAM

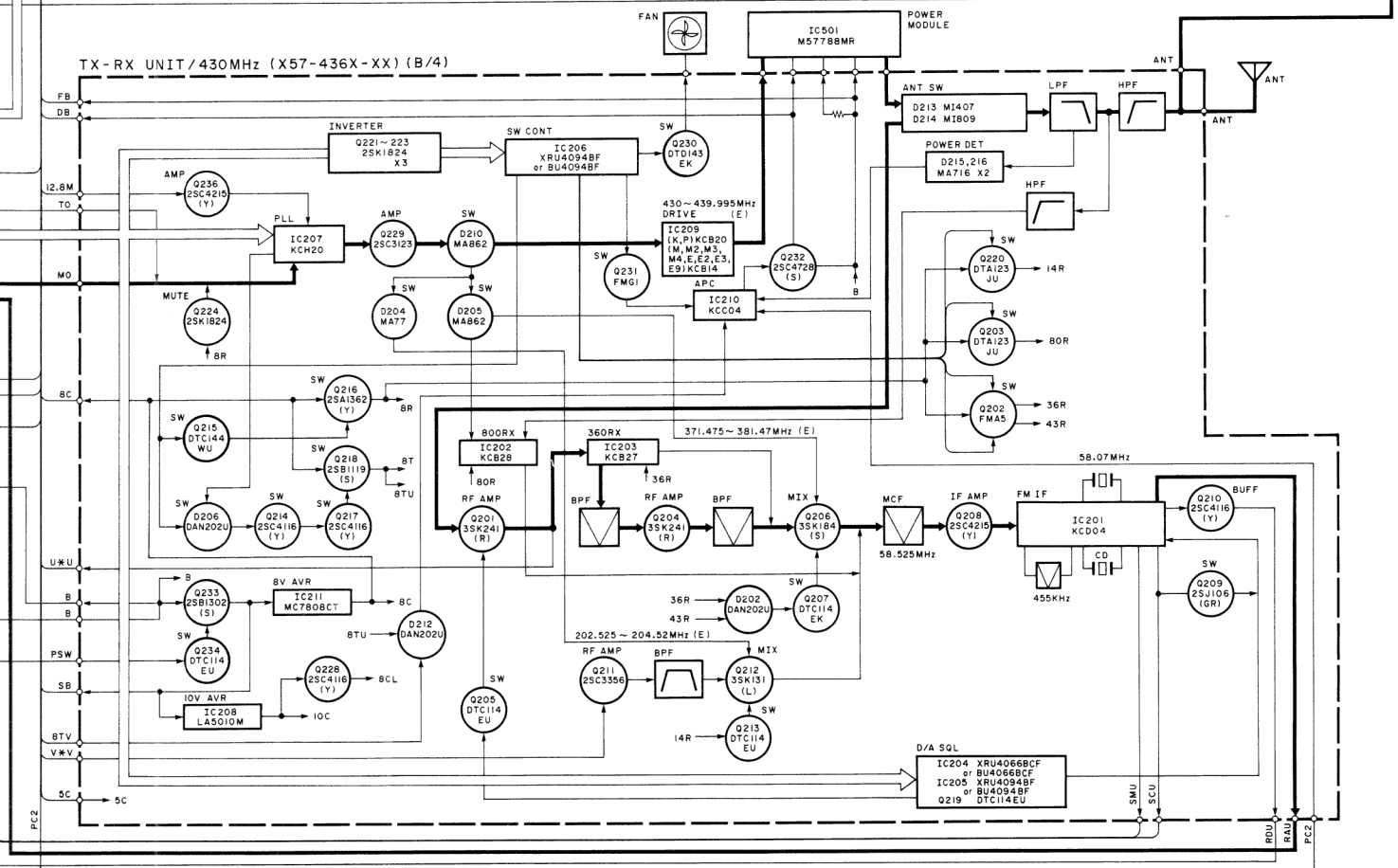
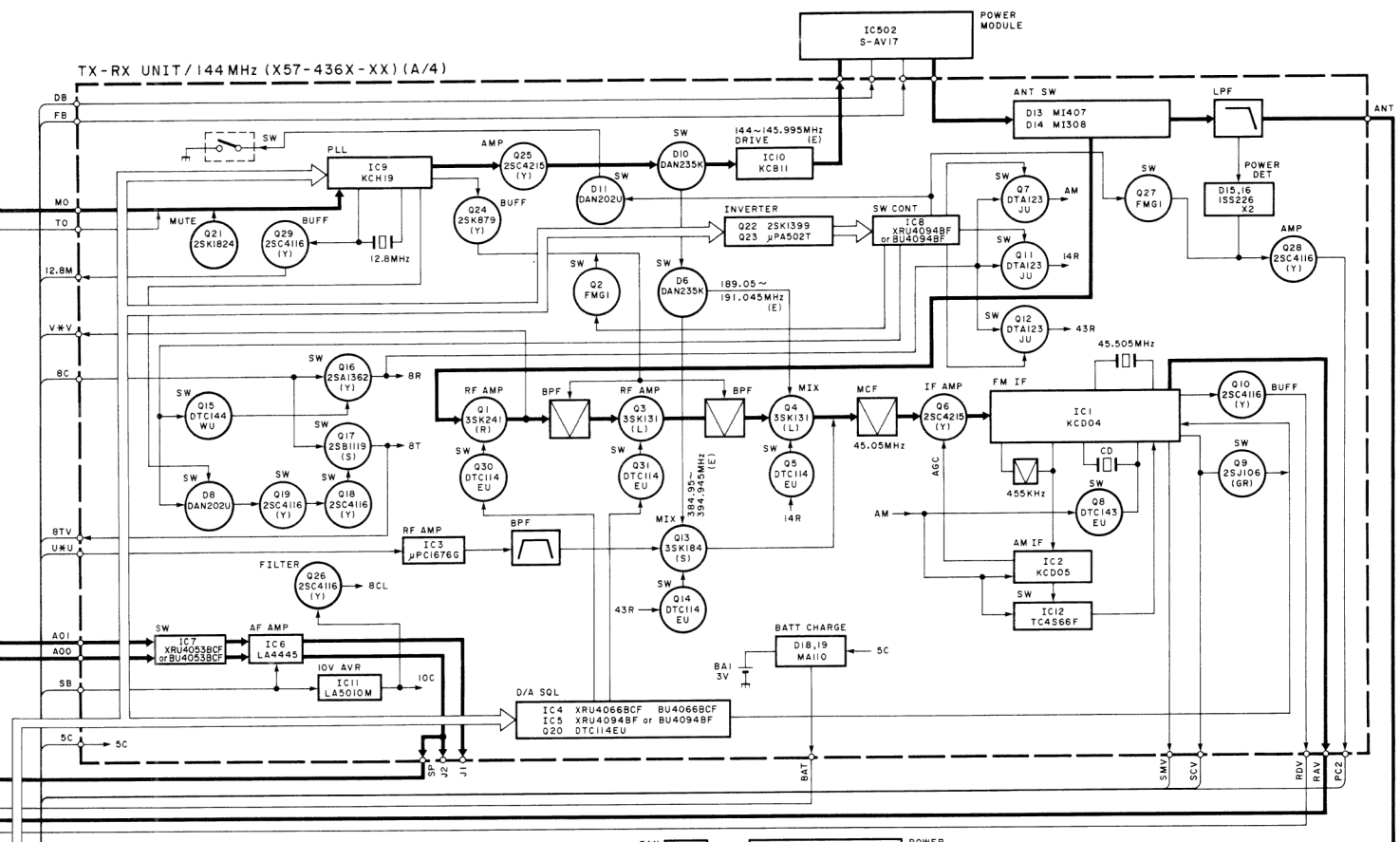

LEVEL DIAGRAM

Transmitter Section

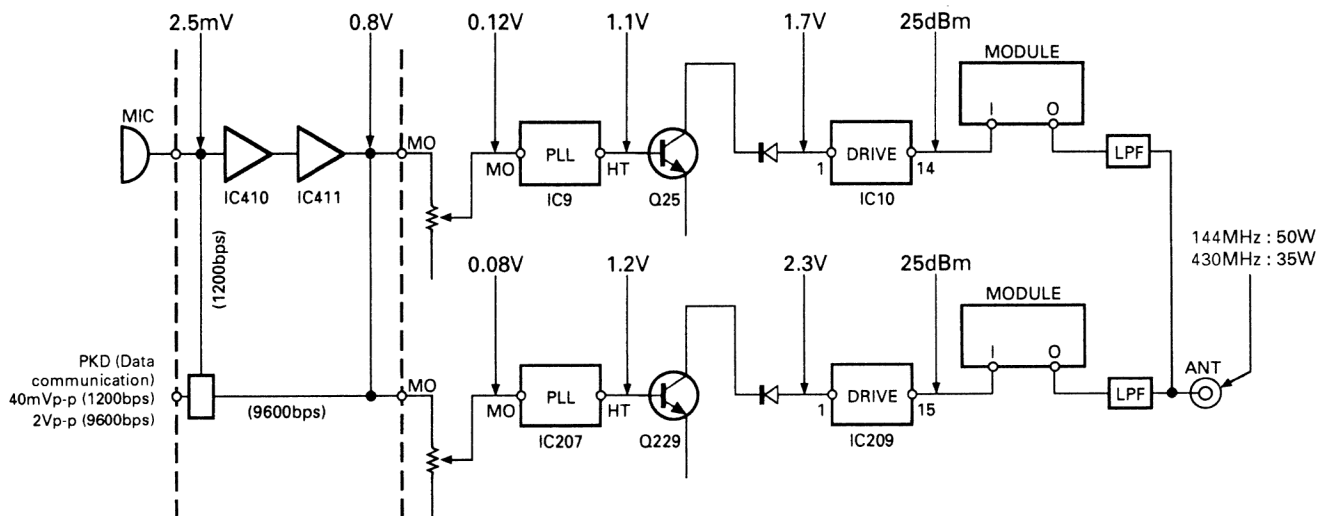

Note 1: Set the AG so that the microphone socket input is 3kHz deviation at 1kHz modulation.
 The data communication connector input level is 3kHz deviation at 1kHz modulation for 1200bps and 2kHz deviation at 1kHz modulation for 9600bps.

Note 2: The transmit frequency is 145.0 or 435.0MHz.
 Note 3: The HI/MID/LOW switch is set to HI.
 Note 4: The measurements with the power meter, except for the ANT connector, are the values with the APC off.
 Note 5: The voltages are RMS values unless otherwise specified.

Receiver Section

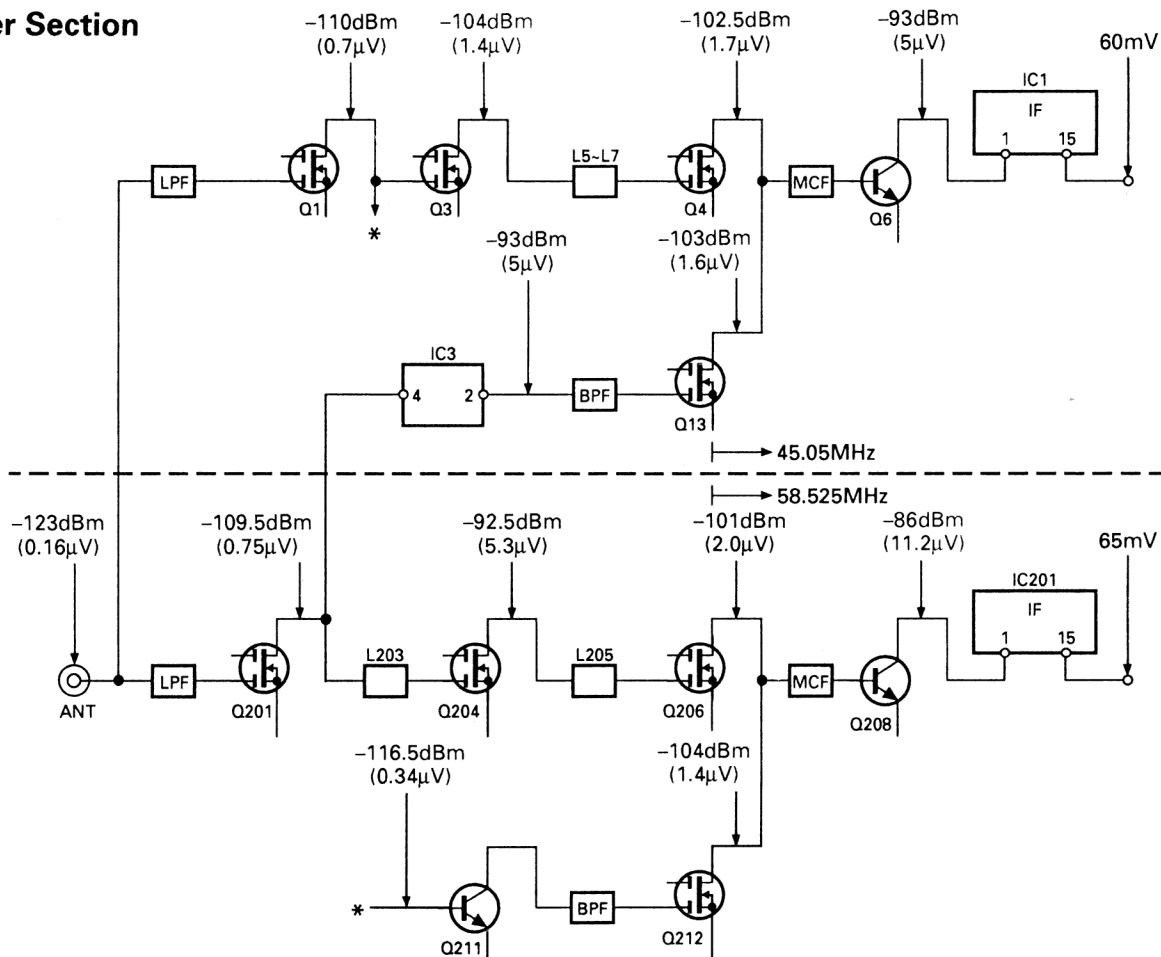

Note 1: The 12dB SINAD levels were plotted using a standard signal generator through a 0.01µF ceramic capacitor at each point from the RF to the first IF.

Note 2: The AF levels were measured with an AF voltmeter when the -73dBm (50µV) standard signal generator signal modulated by a 1kHz modulation frequency and a 3kHz deviation was received and the AF output was adjusted to 0.63V/8Ω by the AF VR.

TERMINAL FUNCTION

CN No.	Pin No.	Name	Function	CN No.	Pin No.	Name	Function	
CN1	1	E	GND.		6	B	13.8V.	
	2	AOI	Internal speaker audio signal input.		7	B	13.8V.	
	3	AOO	External speaker audio signal input.		8	TO	Sub-tone modulation signal output.	
	4	AGCV	AGC voltage output.		9	MO	Modulation signal output.	
	5	ESV1	VHF-band shift register enable (IC8).		10	5C	Common 5V.	
	6	SB	Switched +B input.		11	E	GND.	
	7	ESV2	VHF-band shift register enable (IC5).		12	DTU	UHF-band data output.	
	8	5C	Common 5V.		13	CKU	UHF-band clock output.	
	9	CKV	VHF-band clock input.		14	EPU	UHF-band PLL enable output.	
	10	8C	Common 8V.		15	ESU1	UHF-band shift register enable output (IC206).	
	11	DTV	VHF-band data input.		16	ESU2	UHF-band shift register enable output (IC205).	
	12	EPV	VHF-band PLL enable input.		17	SCU	UHF-band squelch busy control input.	
	13	TO	Sub-tone modulation input.		18	SMU	UHF-band S-meter signal input.	
	14	MO	Modulation signal input.		19	RDU	UHF-band de-modulation signal input.	
	15	RAV	VHF-band audio signal output.		20	RAU	UHF-band audio signal input.	
	16	RDV	VHF-band de-modulation signal output.		21	E	GND.	
	17	SMV	VHF-band S-meter signal output.		CN402	1	BAT	Backup power supply input.
	18	SCV	VHF-band squelch busy control output.			2	SCV	VHF-band squelch busy control input.
	19	BAT	Backup power supply output.			3	SMV	VHF-band S-meter signal input.
CN2	1	E	GND.			4	RDV	VHF-band de-modulation signal input.
	2	SP	Speaker output.			5	RAV	VHF-band audio signal input.
CN3	1	PC2	VHF-band APC output.	6		MO	Modulation signal output.	
	2	8TV	VHF-band 8T output.	7		TO	Sub-tone modulation signal output.	
	3	12.8M	12.8MHz output.	8		EPV	VHF-band PLL enable output.	
	4	E	GND.	9		DTV	VHF-band data output.	
	5	VxV	V ² output.	10		8C	Common 8V.	
	6	E	GND.	11		CKV	VHF-band clock output.	
	7	UxU	U ² input.	12		5C	Common 5V.	
CN201	1	FAN2	SB input for fan.	13		ESV2	VHF-band shift register enable (IC5).	
	2	FAN1	Fan GND.	14		SB	Switched +B output.	
CN202	1	PC2	VHF-band APC input.	15		ESV1	VHF-band shift register enable (IC8).	
	2	8TV	VHF-band 8T input.	16		AGCV	AGC voltage input.	
	3	12.8M	12.8MHz input.	17		AOO	External speaker audio signal output.	
	4	E	GND.	18		AOI	Internal speaker audio signal output.	
	5	VxV	V ² input.	19		E	GND.	
	6	E	GND.	CN403	1	PSI	Serial data input.	
	7	UxU	U ² output.		2	PSO	Serial data output.	
CN203	1	E	GND.		3	E	GND.	
	2	RAU	UHF-band audio signal output.		4	B	13.8V.	
	3	RDU	UHF-band de-modulation signal output.	CN404	1	CK	CTCSS clock output.	
	4	SMU	UHF-band S-meter signal output.		2	DT	CTCSS data output.	
	5	SCU	UHF-band squelch busy control output.		3	CTE	CTCSS enable output.	
	6	ESU2	UHF-band shift register enable input (IC205).		4	TO	Not used.	
	7	ESU1	UHF-band shift register enable input (IC206).		5	SDO	CTCSS tone matched signal input.	
	8	EPU	UHF-band PLL enable input.		6	E	GND.	
	9	CKU	UHF-band clock input.		7	5C	Common 5V.	
	10	DTU	UHF-band data input.		8	RD	CTCSS de-modulation signal output.	
	11	E	GND.	CN601	1	SQV	VHF-band squelch output.	
	12	5C	Common 5V.		2	VOLV	VHF-band volume output.	
	13	MO	Modulation signal input.		3	BSV	VHF-band band select switch output.	
	14	TO	Sub-tone modulation signal input.		4	VCC	5V.	
	15	B	13.8V.		5	GND	GND.	
	16	B	13.8V.	CN602	1	SQU	UHF-band squelch output.	
	17	PSW	Power switch control signal input.		2	VOLU	UHF-band volume output.	
	18	SB	Switched +B output.		3	BSU	UHF-band band select switch output.	
	19	SB	Switched +B output.		4	VCC	5V.	
	20	E	GND.		5	GND	GND.	
	CN401	1	8C	Common 8V input.	CN603	1	MHZ	MHz key output.
2		E	GND.	2		GND	GND.	
3		SB	Switched +B input.	3		A	Encoder output.	
4		SB	Switched +B input.	4		COM	GND.	
5		PSW	Power switch control signal output.	5		B	Encoder output.	

OPTION (DFK-3B/4B/7B)

DFK-3B : Panel Separate Cable (3m)

• External view

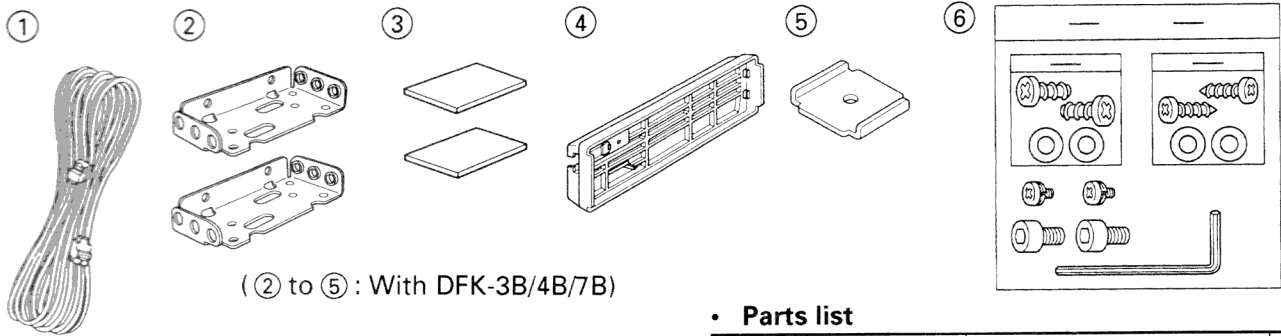

• Parts list

New parts	Parts No.	Description	Fig. No.
*	A62-0306-12	Panel assy	④
*	E30-3189-05	Panel cable (3m)	①
700	G13-1393-04	Cushion	③
*	J21-4457-04	Mounting hardware	⑤
	J29-0475-04	Bracket	②
*	N99-0381-15	Screw set	⑥

DFK-4B : Panel Separate Kit (4m)

• External view

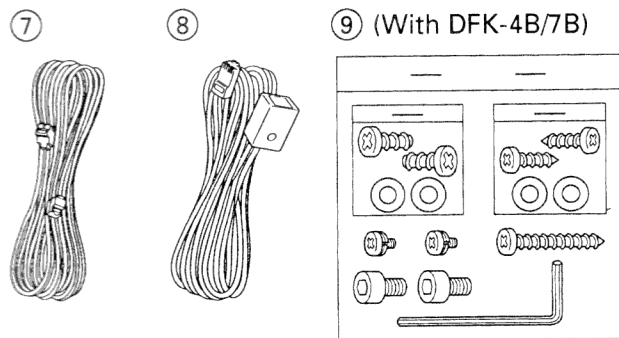

• Parts list

New parts	Parts No.	Description	Fig. No.
*	A62-0306-12	Panel assy	④
*	E30-3151-05	Microphone cable (4m)	⑧
*	E30-3190-05	Panel cable (4m)	⑦
700	G13-1393-04	Cushion	③
*	J21-4457-04	Mounting hardware	⑤
	J29-0475-04	Bracket	②
*	N99-0389-15	Screw set	⑨

DFK-7B : Panel Separate Kit (7m)

• External view

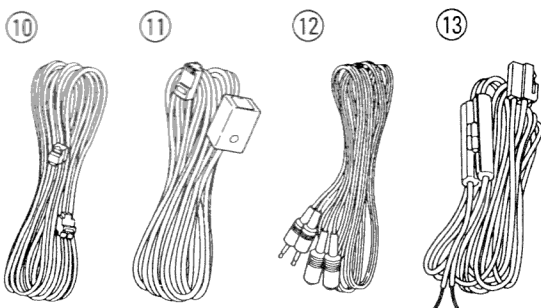

• Parts list

New parts	Parts No.	Description	Fig. No.
*	A62-0306-12	Panel assy	④
*	E30-3153-05	Microphone cable (7m)	⑪
*	E30-3191-05	Speaker cable (5m)	⑫
*	E30-3192-05	Panel cable (7m)	⑩
*	E30-3199-05	DC power cable (6m)	⑬
	F51-0018-05	Fuse (20A)	
700	G13-1393-04	Cushion	③
*	J21-4457-04	Mounting hardware	⑤
	J29-0475-04	Bracket	②
*	N99-0389-15	Screw set	⑨

TM-733A/E

SPECIFICATIONS

Specifications are subject to change without notice due to development in technology.

General

		144MHz Band	430/440MHz Band
Frequency range	U.S.A. Canada	144~148MHz	438~450MHz
	General	144~148MHz	430~440MHz
	TM-733E	144~146MHz	430~440MHz
Mode	F3E (FM)		
Antenna impedance	50Ω		
Usable temperature range	-20°C~+60°C (-4°F~140°F)		
Power supply	13.8V DC ±15% (11.7~15.8V)		
Grounding method	Negative ground		
Current	Transmit (max.)	11.5A or less	10.0A or less
	Receive (no signal)	1.2A or less	
Frequency stability	Within ±10ppm		
Dimensions (W x H x D projections included)	141 x 42 x 165mm		
	5.55" x 1.65" x 6.50"		
Weight	1.1kg/2.4lb		

Transmitter

Power output	High	50W	35W
	Mid	10W	
	Low	Approx. 5W	
Modulation	Reactance		
Spurious emissions	-60dB or less		

	144MHz Band	430/440MHz Band
Maximum frequency deviation	±5kHz	
Audio distortion (at 60% modulation)	3% or less	
Microphone impedance	600Ω	

Receive

Circuitry	Double conversion superheterodyne	
Intermediate frequency (1st/2nd)	45.05MHz /455kHz	58.525MHz /455kHz
Sensitivity (12dB SINAD)	V or U band	0.16μV or less
	V ² or U ² band	0.25μV or less
Selectivity (-6dB)	12kHz or more	
Selectivity (-60dB)	28kHz or less	
Squelch sensitivity	0.1μV or less	
Audio output (8Ω, 5% distortion)	2W or higher	
Audio output impedance	8Ω	

Note : Receiver specifications apply only when using the V or U band. They do not apply to the V² or U² band.

KENWOOD CORPORATION

14-6, Dogenzaka 1-chome, Shibuya-ku, Tokyo 150, Japan

KENWOOD SERVICE CORPORATION

P.O. BOX 22745, 2201 East Dominguez Street, Long Beach, CA 90801-5745, U.S.A.

KENWOOD ELECTRONICS DEUTSCHLAND GMBH

Rembrücker Str. 15, 6056 Heusenstamm, Germany

KENWOOD ELECTRONICS BENELUX N.V.

Mechelsesteenweg 418 B-1930 Zaventem, Belgium

TRIO-KENWOOD FRANCE S.A.

13, Boulevard Ney, 75018 Paris, France

TRIO-KENWOOD U.K. LIMITED

KENWOOD House, Dwight Road, Watford, Herts., WD1 8EB United Kingdom

KENWOOD ELECTRONICS NEDERLAND B.V.

Amsterdamseweg 35, 1422 AC Uithoorn, The Netherlands

KENWOOD ELECTRONICS ITALIA S.p.A.

Via G. Sirtori, 7/9 20129 Milano, Italy

KENWOOD ESPAÑA S.A.

Bolivia, 239-08020 Barcelona, Spain

KENWOOD ELECTRONICS AUSTRALIA PTY. LTD.

(A.C.N. 001 499 074)

P.O. Box 504, 8 Figtree Drive, Australia Centre, Homebush, N.S.W. 2140, Australia

KENWOOD & LEE ELECTRONICS, LTD.

Unit 3712-3724, Level 37, Tower one Metroplaza, 223 Hing Fong Road, Kwai Fong, N.T., Hong Kong

KENWOOD ELECTRONICS CANADA INC.

6070 Kestrel Road, Mississauga, Ontario, Canada L5T 1S8